

PSR / PSL series

kamo



NEW

精緻かつ強固な差動減速機構を内蔵した超薄型減速機
Ultrathin speed reducer with a built-in elaborate, strong differential reduction mechanism

KAMO SEIKO CORP.

PSRシリーズとは What Is the PSR Series?

PSRシリーズ(Pancake Speed Reducer Series)とは、円周上に配置されたローラの内側に、高い信頼性を誇るトロコイドギアを二枚の堅牢精緻な超薄形として対向配置し、かつ巧妙なピン&ホール方式とクロスローラベアリング支持により出力する、洗練されたデザインのパンケーキ形超薄型差動減速機です。

PSR Series (Pancake Speed Reducer Series) is a series of sophisticatedly designed pancake-shaped ultrathin differential speed reducers. Rollers are circumferentially placed, and on the inward side of the rollers, a pair of trochoid gears, which boast high reliability, are placed oppositely, forming a robust, precise and ultrathin component. Power from an input axis is outputted from an output axis through an elaborate pin-and-hole mechanism and a cross-roller bearing support.

特徴 Features

■ 超扁平&コンパクト Ultra-flat and compact

差動式減速機構と薄形クロスローラベアリングの採用により超扁平形を可能としました。装置の短縮とコンパクト化に貢献します。
The adoption of a differential reduction mechanism and a thin cross-roller bearing has enabled an ultra-flat form. This contributes to the realization of contraction and compactification of equipment.

■ 高剛性 High rigidity

かみ合い率が高く負荷が分散されるため剛性が極めて高いです。
High contact ratio and load dispersion have realized extremely high rigidity.

■ 低バックラッシ Small backlash

各部クリアランスの最適化によりバックラッシ3 arcmin以下の高精度位置決めが可能です。
The optimization of each part clearance enables high-precision positioning with the backlash of 3 arcmin or less.

■ メンテナンスフリー Maintenance-free

グリース封入でメンテナンスフリーです。給油の必要は無く、取付姿勢の制限もありません。
Grease inclusion has eliminated the need of maintenance. There is no need of greasing, and there is no limiting to mounting posture.

■ 軽量 (PSL) Light Weight (PSL)

主要部品にアルミを採用した軽量モデルを追加。従来品に対して30%の軽量化を果たしました。
PSR70FCA 0.62kg → PSL70FCA 0.42kg
Released the light weight model "PSL" which is used Aluminium to the main construct part for Reducer. This is realized to decrease the mass about 30% from the conventional model.

■ 高精度 High precision

精密トロコイドギアと高精度ローラの複数かみ合いにより高い伝達精度を実現しました。
Plural meshing of precision trochoid gears and high-precision rollers has realized high-precision transmission.

■ 高効率 High efficiency

適性の圧力角設定でスムーズな動作かつ高効率です。
Appropriate pressure angle setting has made operation smooth and highly efficient.

■ モータ簡単取付 Easy-to-mount motor

各社サーボモータ用のモータアタッチメントがあり、購入後すぐにモータを取り付けることができます。
Motor attachments designed for servo motors of various manufacturers are available to enable the immediate motor mounting after purchase.

構造 Structure

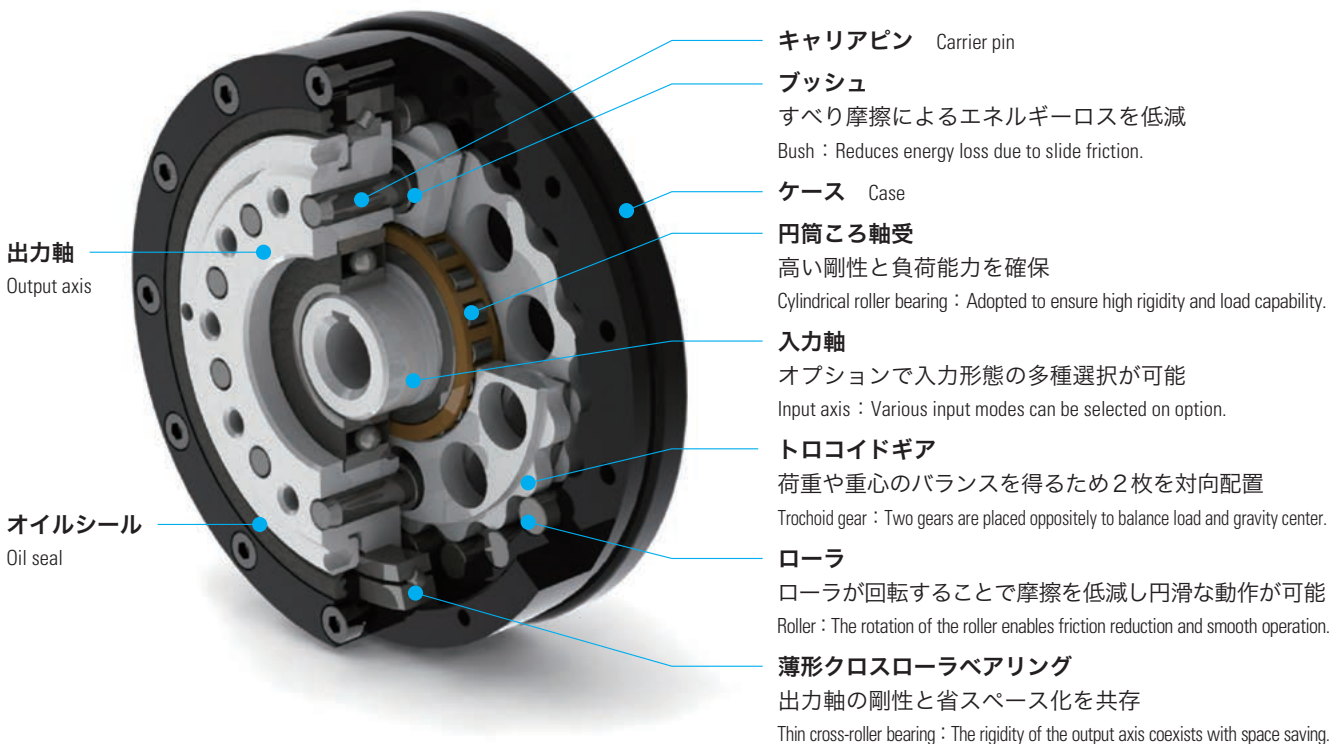

作動原理 Operating Principle

差動減速機構部 Differential reduction mechanism

ケースに嵌り回転するローラで構成する内歯車と、入力軸の偏心部に軸受を介して支持されるトロコイドギアからなる差動減速機構です。入力軸を1回転させるとトロコイドギアが公転するとともに反対方向へ1歯分自転します。この入力軸とトロコイドギアの回転量が速比となります。

The differential reduction mechanism consists of internal gears and trochoid gears, where the internal gears are made up of encased rollers, and the trochoid gears are supported by the eccentric part of the input axis through bearings. When the input axis is rotated by one turn, the trochoid gears revolve and, at the same time, reversely rotate by the amount equivalent to one gear tooth (circle pitch). The ratio between the rotation amount of the input axis and the revolution amount of the trochoid gears constitutes the speed reduction ratio.

速比 Speed ratio : $\frac{1}{R} = 1 - \frac{Z_2}{Z_1}$ Z_1 : トロコイドギア歯数 Number of trochoid gear teeth Z_2 : ローラ本数 Number of rollers

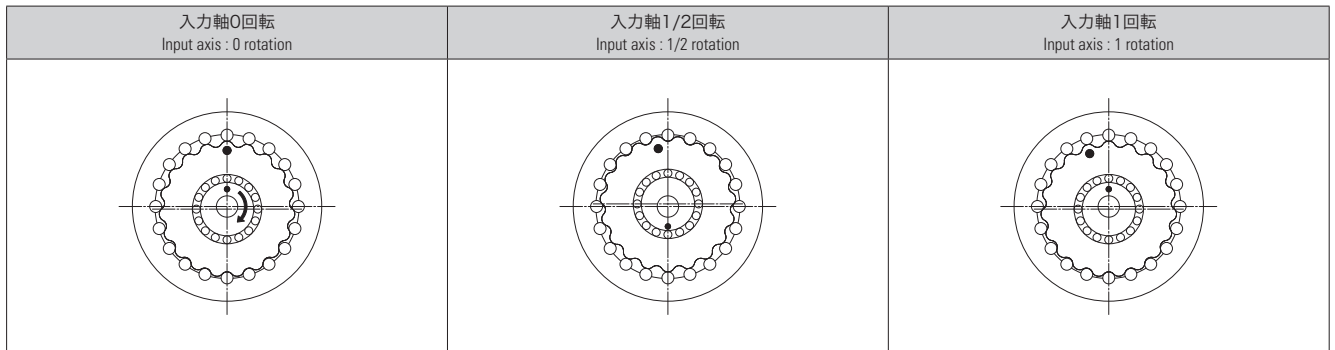

偏心等速機構部 Eccentric constant speed mechanism

差動減速機構で発生するトロコイドギアの公転と自転のうち、自転のみを出力軸に伝えるのが偏心等速機構です。出力軸に固定された数本のキャリアピンにブッシュが嵌っており、トロコイドギアに設けられた小ホールがブッシュに接触しながら公転することにより自転のみを等速に出力軸へ伝えます。

The eccentric constant speed mechanism transmits only the rotation, out of the revolution and rotation of the trochoid gears generated by the differential reduction mechanism, to the output axis. In each of several pieces of carrier pins fixed to the output axis, bushes are fitted. When the trochoid gears revolve with their small holes in contact with the bushes, only the rotation of the trochoid gears is transmitted to the output axis at the constant speed.

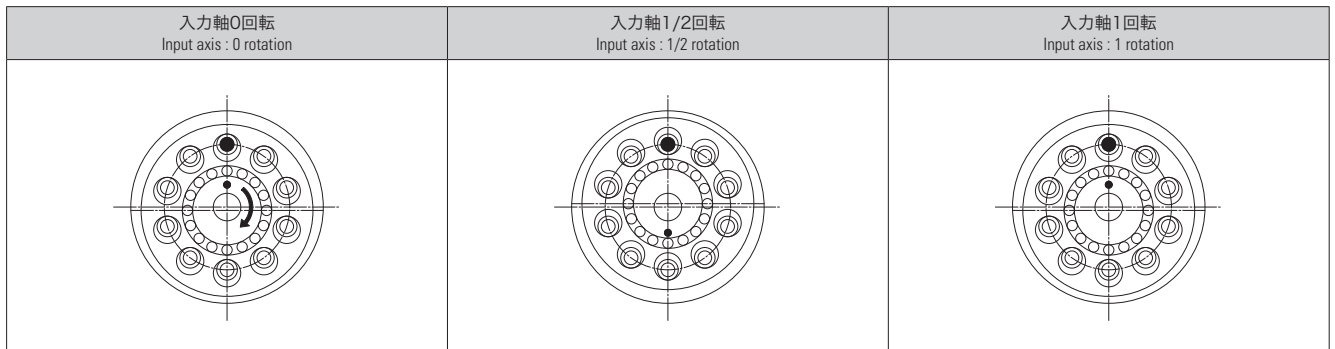

PSRシリーズの内部機構 Inner mechanism of PSR Series

差動減速機構と偏心等速機構により入力軸の回転を正確かつ円滑に減速して出力軸へ伝えます。

The rotation speed of the input axis is reduced precisely and smoothly by the differential reduction mechanism, and transmitted to the output axis by the eccentric constant speed mechanism.

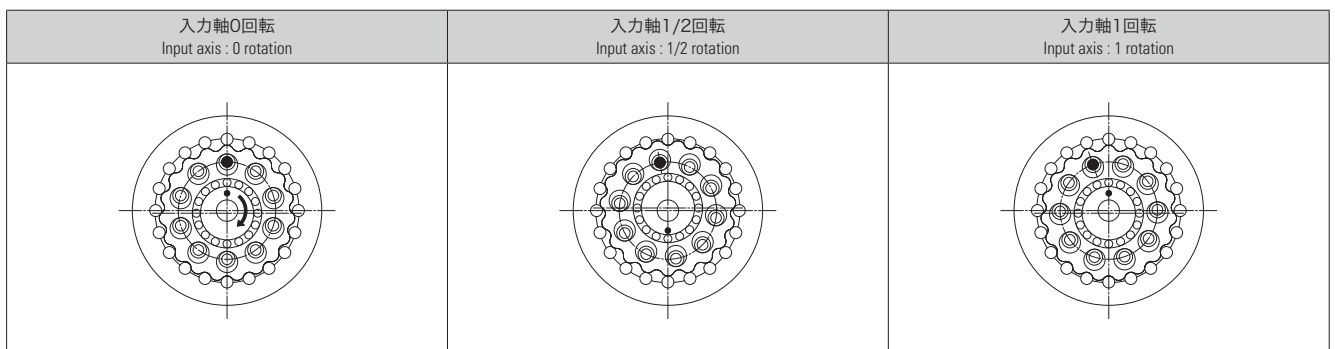

用途例 Use Examples

● モビリティ Mobility



● 探査機 Probe vehicle



● 多関節ロボット Articulated robot



● スカラロボット SCARA robot



● ヒューマノイドロボット Humanoid robot



● アシストスーツ Assist suit



● 介護・福祉機器 Care and welfare equipment



● TCGシリーズとの組み合わせ Combination with TCG Series

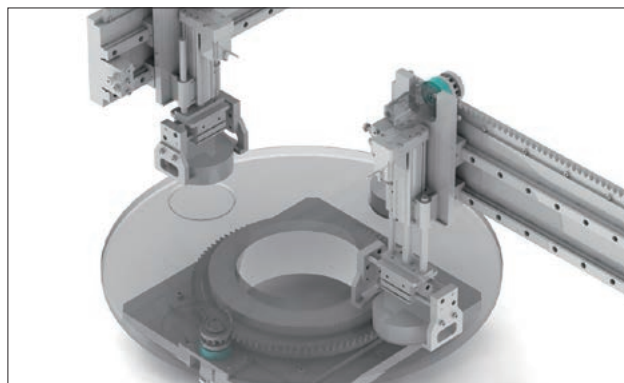

仕様・寸法表

Specifications / Dimensional Tables

PSR

Standard model

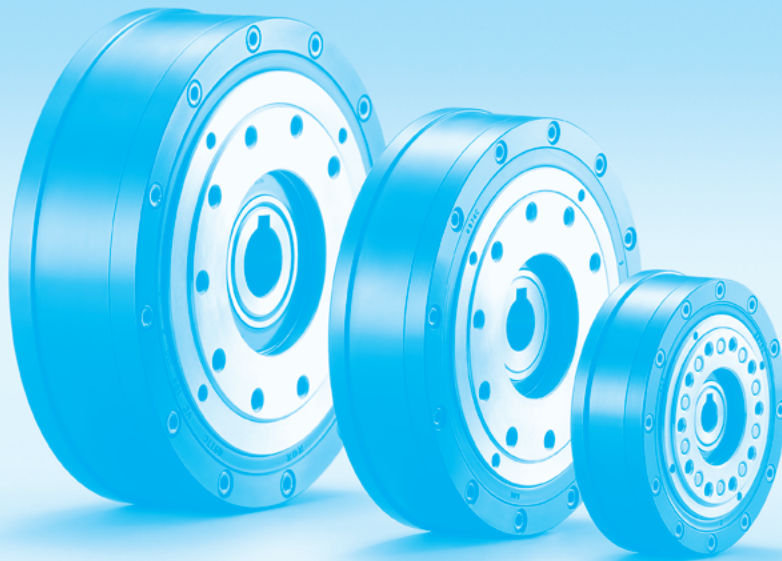

仕様・型式・外形図 Specifications, Models and Outline Drawings

PSR仕様 PSR Specifications

型式 Model	PSR70			PSR110			PSR135					
減速比 Reduction ratio	19	39	49	19	39	59	19	39	59			
入力軸に対する出力軸の回転方向 Rotational direction of output axis to input axis	逆方向 Reverse direction			逆方向 Reverse direction			逆方向 Reverse direction					
許容定格トルク Allowable rated torque	N・m			16	26	26	32	65	65	65	130	130
加速時ピークトルク Accelerating peak torque	N・m			32	52	52	65	130	130	130	260	260
瞬時最大トルク Maximum instantaneous torque	N・m			48	90	96	96	195	195	195	390	390
許容平均入力回転数 Allowable average rotational speed	rpm			3000			3000			3000		
最高入力回転数 Maximum rotational speed	rpm			4500			4500			4500		
バックラッシュ Backlash	arcmin			4			3			3		
推奨モータ容量 Recommended motor capacity	W			100			200・400			750		
入力軸換算慣性モーメント Input axis equivalent inertia moment	$\times 10^{-4} \text{kg} \cdot \text{m}^2$			0.037	0.036	0.036	0.310	0.298	0.295	1.337	1.295	1.287
入力軸穴径 Input axis hole diameter	mm			6・8			8・10・11・14			14・16・19		
質量(モータアタッチメントなし) Mass (without motor attachment)	kg			0.6			2.1			4.1		

連続回転にて使用される場合は弊社にご相談ください。
When you intend to use in continuous recollection, please contact to us.

型式表示 Model Indication

● PSR型式 Model PSR

PSR 110 F H A - 59 - C01 08

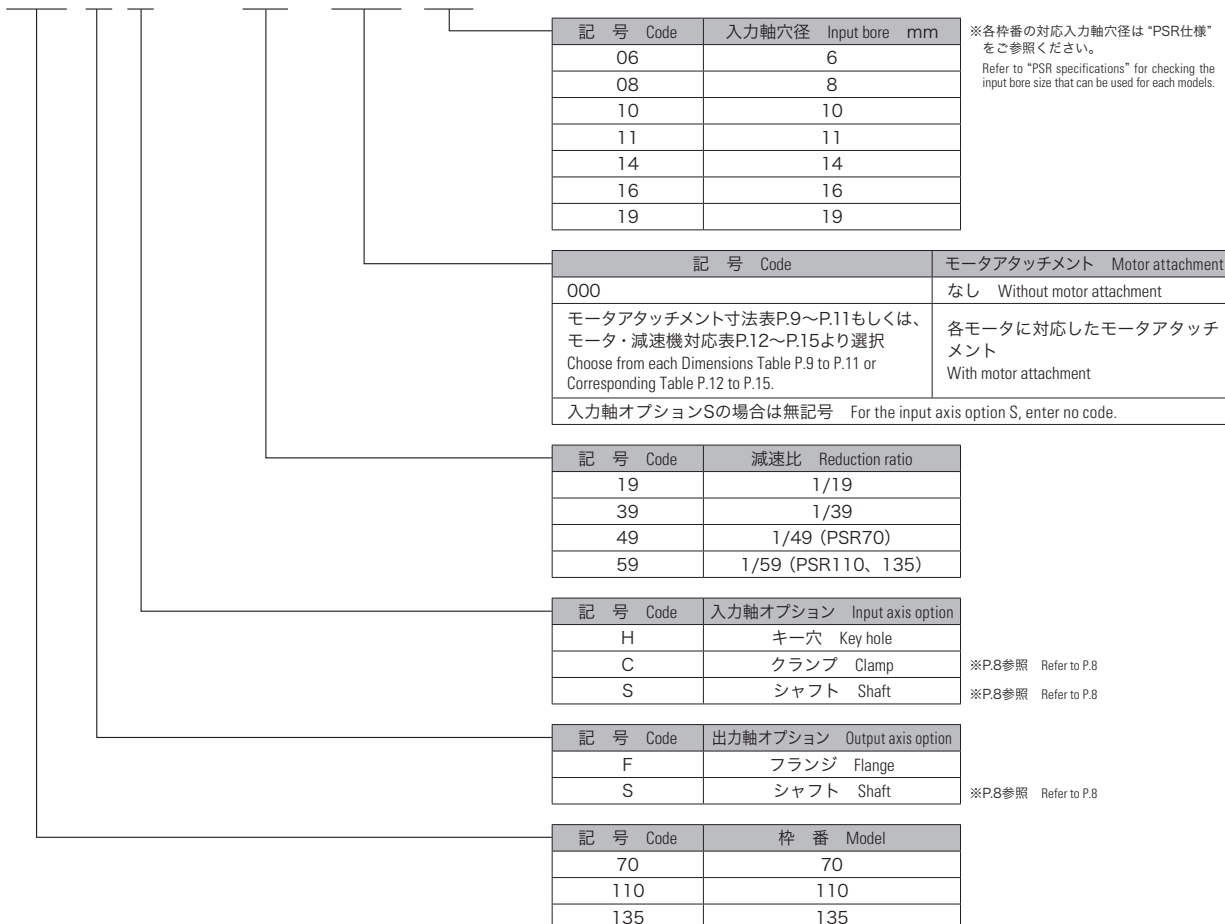

外形寸法図 Outline dimensional drawings

● PSR70FHA-□□-00008

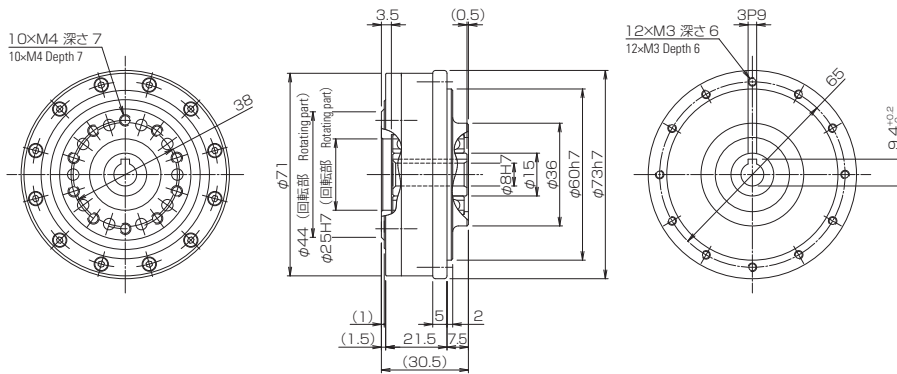

● PSR110FHA-□□-000□□

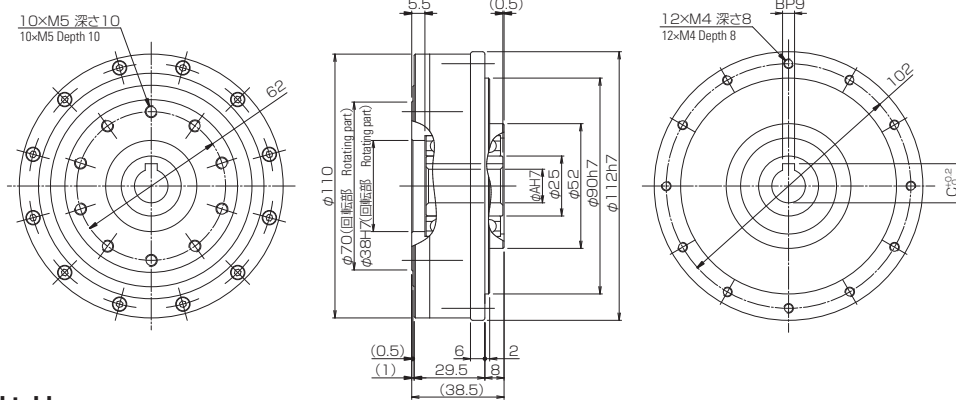

寸法表 Dimensional table

型式 Model	A	B	C
PSR110FHA-□□-00008	8	3	9.4
PSR110FHA-□□-00010	10	3	11.4
PSR110FHA-□□-00011	11	4	12.8
PSR110FHA-□□-00014	14	5	16.3

● PSR135FHA-□□-000□□

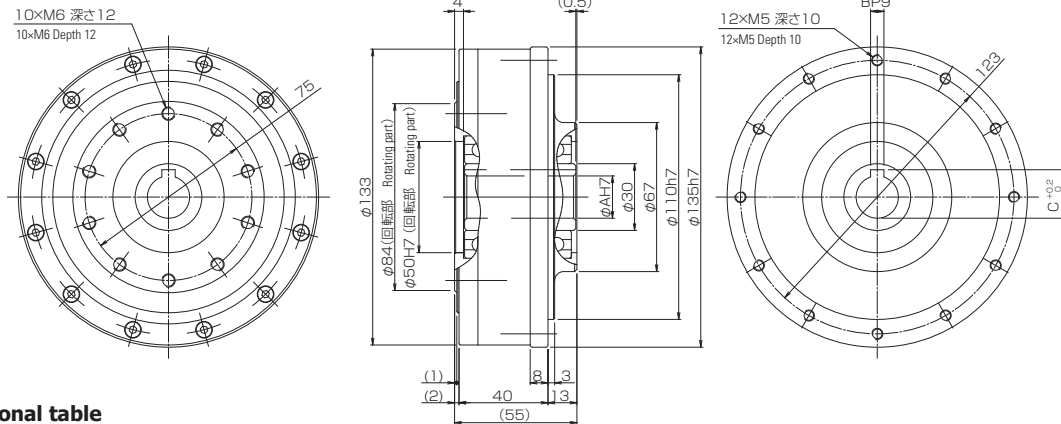

寸法表 Dimensional table

型式 Model	A	B	C
PSR135FHA-□□-00014	14	5	16.3
PSR135FHA-□□-00016	16	5	18.3
PSR135FHA-□□-00019	19	6	21.8

オプション 入力と出力の形態に設計の自由度があります。
Option Both the input mode and the output mode have the degree of freedom in design.

● 出力軸オプションS(シャフト) Output axis option S (shaft)

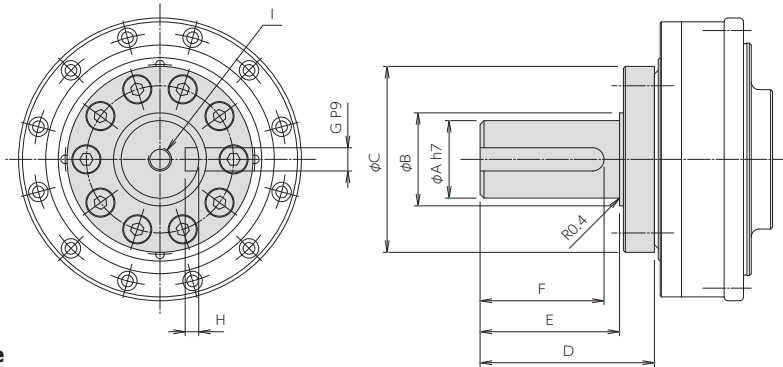

寸法表 Dimension table

型式 Model	A	B	C	D	E	F	G	H	I
PSR70□A-□□-□□□□□□	20	24	48	45	36	32	6	3.5 ^{+0.1} ₀	M6 深さ12 M6 Depth 12
PSR110□A-□□-□□□□□□	30	34	74	68	58	50	8	4 ^{+0.2} ₀	M8 深さ16 M8 Depth 16
PSR135□A-□□-□□□□□□	35	39	88	69	58	50	10	5 ^{+0.2} ₀	M10 深さ20 M10 Depth 20

● 入力軸オプションC(クランプ) Input axis option C (clamp)

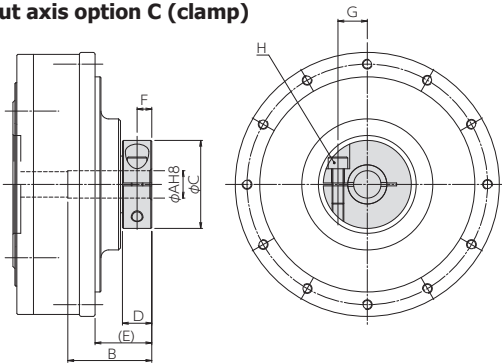

● 入力軸オプションS(シャフト) Input axis option S (shaft)

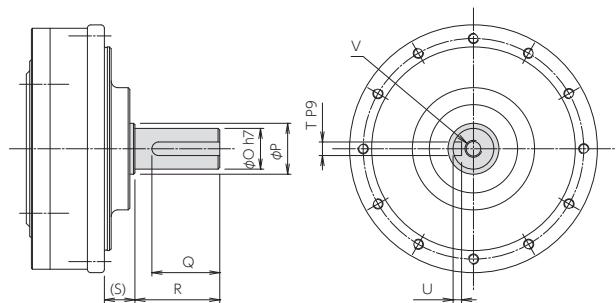

寸法表 【入力軸オプションC(クランプ)】 Dimension table [Input axis option C (clamp)]

型式 Model	A	B	C	D	E	F	G	H
PSR70□CA-□□-□□□□06	6	17.5	30	8	16.5	4	10	M3
PSR70□CA-□□-□□□□08	8	23.5	30	8	16.5	4	10	M3
PSR110□CA-□□-□□□□08	8	21.5	30	10	19	5	10	M4
PSR110□CA-□□-□□□□10	10	21.5	40	10	19	5	14	M5
PSR110□CA-□□-□□□□11	11	26.5	40	10	19	5	14	M5
PSR110□CA-□□-□□□□14	14	34.5	40	10	19	5	14	M5
PSR135□CA-□□-□□□□14	14	26.5	45	15	29	7.5	15	M6
PSR135□CA-□□-□□□□16	16	36.5	45	15	29	7.5	15	M6
PSR135□CA-□□-□□□□19	19	36.5	50	15	29	7.5	18	M6

寸法表 【入力軸オプションS(シャフト)】 Dimension table [Input axis option S (shaft)]

型式 Model	O	P	Q	R	S	T	U	V	許容ラジアル荷重 N Allowable radial load N
PSR70□SA-□□	12	15	20	25	9	4	2.5 ^{+0.1} ₀	M5 深さ10 M5 Depth 10	150
PSR110□SA-□□	16	25	25	28	9.5	5	3 ^{+0.1} ₀	M6 深さ12 M6 Depth 12	250
PSR135□SA-□□	25	30	36	42	14.5	8	4 ^{+0.2} ₀	M8 深さ16 M8 Depth 16	500

オプション 駆動モータを取り付けるためのモータアタッチメントです。モータメーカー及び型式に合わせてお選び下さい。
Option These options are motor attachments for mounting drive motors. Select one according to the motor manufacturer and model.

● **モータアタッチメント Motor attachment**

モータアタッチメントの材質はアルミ合金(A2017)です。
 The material of the motor attachment is aluminum alloy (A2017).

記号 Code : A□□・C□□・E□□

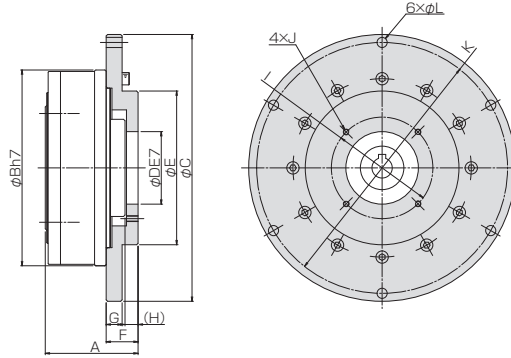

寸法表 Dimensional table

型式 Model	記号 Code	A	B	C	D	E	F	G	H	I	J	K	L	質量 kg Mass
PSR70	A01	34.5	73	94	22	56	11.5	8	4.5	48	M3 深さ6 M3 Depth 6	86	4.5	0.13
	A02	34.5	73	94	30	56	11.5	8	4.5	45	M3 深さ6 M3 Depth 6	86	4.5	0.13
	A03	34.5	73	94	30	56	11.5	8	4.5	46	M4 深さ8 M4 Depth 8	86	4.5	0.13
PSR110	C01	47.5	112	139	22	77	17	9	9.5	48	M3 深さ6 M3 Depth 6	127	5.5	0.38
	C02	47.5	112	139	30	77	17	9	9.5	45	M3 深さ6 M3 Depth 6	127	5.5	0.38
	C03	47.5	112	139	30	77	17	9	9.5	46	M4 深さ8 M4 Depth 8	127	5.5	0.38
	C04	42.5	112	139	50	77	12	9	4.5	70	M4 深さ8 M4 Depth 8	127	5.5	0.38
	C05	42.5	112	139	50	77	12	9	4.5	70	M5 深さ9 M5 Depth 9	127	5.5	0.38
PSR135	E01	64	135	184	50	106	22	11	9.5	70	M4 深さ8 M4 Depth 8	173	7	0.79
	E02	64	135	184	50	106	22	11	9.5	70	M5 深さ8 M5 Depth 8	173	7	0.79
	E03	59	135	184	70	106	17	11	4.5	90	M5 深さ10 M5 Depth 10	173	7	0.79
	E04	59	135	184	70	106	17	11	4.5	90	M6 深さ12 M6 Depth 12	173	7	0.79

記号 Code : B□□・D□□・F□□・G□□

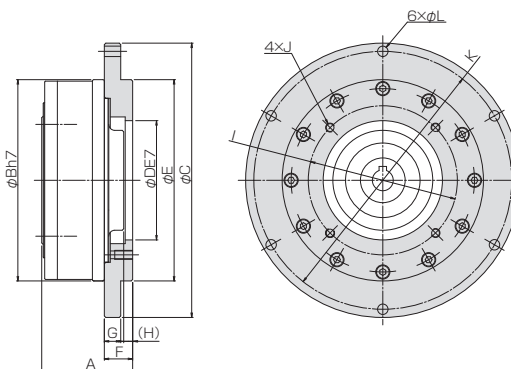

寸法表 Dimensional table

型式 Model	記号 Code	A	B	C	D	E	F	G	H	I	J	K	L	質量 kg Mass
PSR70	B01	34.5	73	94	50	77	11.5	8	4.5	70	M4 深さ8 M4 Depth 8	86	4.5	0.12
	B02	34.5	73	94	50	77	11.5	8	4.5	70	M5 深さ10 M5 Depth 10	86	4.5	0.12
PSR110	D01	42.5	112	139	70	116	12	9	4.5	90	M5 深さ9 M5 Depth 9	127	5.5	0.30
	D02	42.5	112	139	70	116	12	9	4.5	90	M6 深さ9 M6 Depth 9	127	5.5	0.30
	D03	42.5	112	139	80	116	12	9	4.5	100	M6 深さ12 M6 Depth 12	127	5.5	0.30
PSR135	F01	61	135	184	80	135	19	11	6.5	100	M6 深さ12 M6 Depth 12	173	7	0.75
	F02	61	135	184	95	135	19	11	6.5	115	M8 深さ15 M8 Depth 15	173	7	0.75
	G01	62	135	184	110	160	20	11	7.5	145	M8 深さ16 M8 Depth 16	173	7	0.75

オプション 駆動モータを取り付けるためのモータアタッチメントです。モーターメーカー及び型式に合わせてお選び下さい。
Option These options are motor attachments for mounting drive motors. Select one according to the motor manufacturer and model.

記号 Code : L□□・N□□・P□□

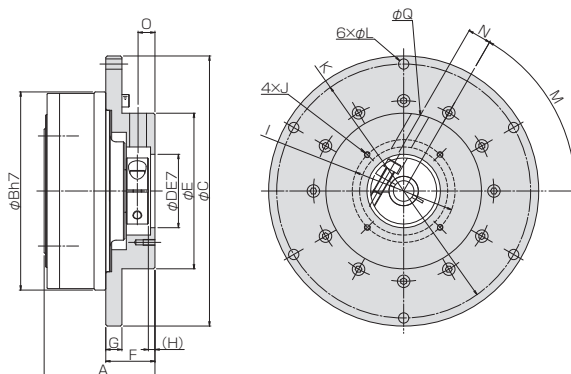

寸法表 Dimensional table

型式 Model	記号 Code	A	B	C	D	E	F	G	H	I	J	K	L	M	N	O	Q	質量 kg Mass
PSR70	L01	44	73	94	22	56	21	8	4.5	48	M3 深さ6 M3 Depth 6	86	4.5	90°	9	8	8.5	0.17
	L02	44	73	94	30	56	21	8	4.5	45	M3 深さ6 M3 Depth 6	86	4.5	90°	9	8	8.5	0.17
	L03	44	73	94	30	56	21	8	4.5	46	M4 深さ8 M4 Depth 8	86	4.5	90°	9	8	8.5	0.17
PSR110	N01	54	112	139	22	77	23.5	9	4.5	48	M3 深さ6 M3 Depth 6	127	5.5	60°	13	9	8.5	0.38
	N02	54	112	139	30	77	23.5	9	4.5	45	M3 深さ6 M3 Depth 6	127	5.5	60°	13	9	8.5	0.38
	N03	54	112	139	30	77	23.5	9	4.5	46	M4 深さ8 M4 Depth 8	127	5.5	60°	13	9	8.5	0.38
	N04	54	112	139	50	77	23.5	9	4.5	70	M4 深さ8 M4 Depth 8	127	5.5	60°	13	9	8.5	0.38
	N05	54	112	139	50	77	23.5	9	4.5	70	M5 深さ9 M5 Depth 9	127	5.5	60°	13	9	8.5	0.38
PSR135	P01	75.5	135	184	50	106	33.5	11	4.5	70	M4 深さ8 M4 Depth 8	173	7	90°	16	11.5	11.5	0.96
	P02	75.5	135	184	50	106	33.5	11	4.5	70	M5 深さ8 M5 Depth 8	173	7	90°	16	11.5	11.5	0.96
	P03	75.5	135	184	70	106	33.5	11	4.5	90	M5 深さ10 M5 Depth 10	173	7	90°	16	11.5	11.5	0.96
	P04	75.5	135	184	70	106	33.5	11	4.5	90	M6 深さ12 M6 Depth 12	173	7	90°	16	11.5	11.5	0.96

記号 Code : M□□・T□□・Q□□・R□□

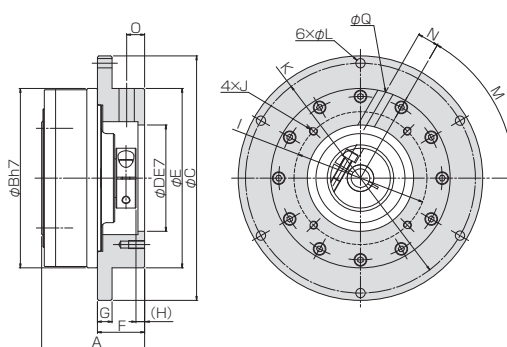

寸法表 Dimensional table

型式 Model	記号 Code	A	B	C	D	E	F	G	H	I	J	K	L	M	N	O	Q	質量 kg Mass
PSR70	M01	44	73	94	50	77	21	8	4.5	70	M4 深さ8 M4 Depth 8	86	4.5	90°	9	8	8.5	0.18
	M02	44	73	94	50	77	21	8	4.5	70	M5 深さ10 M5 Depth 10	86	4.5	90°	9	8	8.5	0.18
PSR110	T01	54	112	139	70	116	23.5	9	4.5	90	M5 深さ10 M5 Depth 10	127	5.5	60°	13	9	8.5	0.48
	T02	54	112	139	70	116	23.5	9	4.5	90	M6 深さ12 M6 Depth 12	127	5.5	60°	13	9	8.5	0.48
	T03	54	112	139	80	116	23.5	9	4.5	100	M6 深さ12 M6 Depth 12	127	5.5	60°	13	9	8.5	0.48
PSR135	Q01	77.5	135	184	80	135	35.5	11	6.5	100	M6 深さ12 M6 Depth 12	173	7	90°	16	13.5	11.5	1.3
	Q02	77.5	135	184	95	135	35.5	11	6.5	115	M8 深さ16 M8 Depth 16	173	7	90°	16	13.5	11.5	1.3
	R01	78.5	135	184	110	160	36.5	11	7.5	145	M8 深さ16 M8 Depth 16	173	7	90°	16	14.5	11.5	1.3

記号 Code : H□□・J□□・K□□

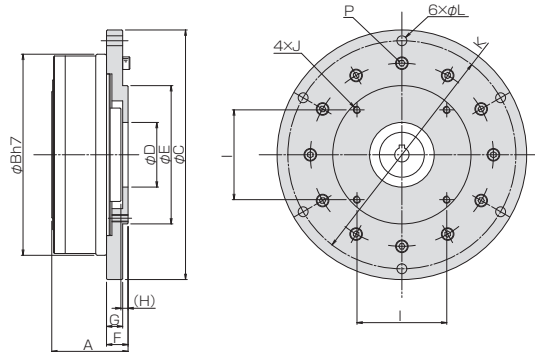

寸法表 Dimensional table

型式 Model	記号 Code	A	B	C	D	E	F	G	H	I	J	K	L	P	質量 kg Mass
PSR70	H01	34.5	73	94	22H7	56	11.5	8	4.5	31	φ3.5	86	4.5	M3	0.12
PSR110	J01	42.5	112	139	36E7	77	12	9	4.5	50	M4 深さ8 M4 Depth 8	127	5.5	—	0.30
	K01	44.5	112	139	60E7	116	14	9	6.5	70	M6 深さ12 M6 Depth 12	127	5.5	—	0.37

※モータアタッチメント：H01はモータ取付後、付属の六角穴付ボルト(M3)で減速機に固定してください。
After combined with your motor and Motor attachment No.H01, please combine it to Reducer by hexagon socket head bolt (M3) we enclosed.

記号 Code : V□□・W□□・Y□□

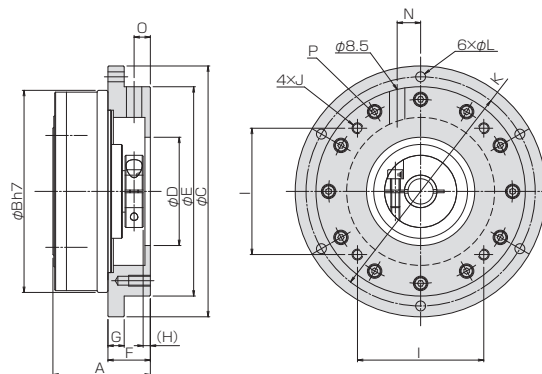

寸法表 Dimensional table

型式 Model	記号 Code	A	B	C	D	E	F	G	H	I	J	K	L	N	O	P	質量 kg Mass
PSR70	V01	44	73	94	22H7	77	21	8	4.5	31	φ3.5	86	4.5	9	8	M3	0.18
PSR110	W01	54	112	139	36E7	77	23.5	9	4.5	50	M4 深さ8 M4 Depth 8	127	5.5	13	9	—	0.37
	Y01	54	112	139	60E7	116	23.5	9	4.5	70	M6 深さ12 M6 Depth 12	127	5.5	13	9	—	0.48

※モータアタッチメント：V01はモータ取付後、付属の六角穴付ボルト(M3)で減速機に固定してください。
After combined with your motor and Motor attachment No.V01, please combine it to Reducer by hexagon socket head bolt (M3) we enclosed.

モータ・減速機対応表 Motor/Reducer Corresponding Table

モータ・減速機対応表は簡易表です。必ず型式選定計算を行ってください。グレー表示の型式は、減速機加速時ピークトルクを超えないようにご使用ください。掲載されていないモータ型式については弊社にお問い合わせください。

Since the Motor and Reduction Ratio Correspondence Table is a simplified presentation, be sure to make a model selecting calculation. Please use so that the peak torque during acceleration of the reducer is not exceeded about the motor mounting Number in gray colour. For any motor model not listed here, please contact us.

三菱電機 Mitsubishi Electric

■の型式は減速機加速時ピークトルクを超えないようにご注意ください。

Please be careful so that the peak torque during acceleration of the reducer is not exceeded about the motor mounting Number in gray colour.

モータ型式		PSR型式・減速比																			
		入力軸：キー穴(標準)									入力軸：クランプ										
		PSR70			PSR110			PSR135			PSR70			PSR110			PSR135				
		19	39	49	19	39	59	19	39	59	19	39	49	19	39	59	19	39	59		
J5	HK-KT	053W	A0308	A0308	A0308			C0308				L0308	L0308	L0308			N0308				
		13W	A0308	A0308	A0308			C0308				L0308	L0308	L0308			N0308				
		1M3W	A0308	A0308	A0308			C0308				L0308	L0308	L0308			N0308				
		13UW	B0208	B0208	B0208			C0508				M0208	M0208	M0208			N0508				
		23W				C0514	C0514	C0514								N0514	N0514	N0514			
		43W				C0514	C0514				E0214					N0514	N0514				P0214
		63W							E0214	E0214	E0214								P0214	P0214	P0214
		23UW				D0214	D0214	D0214								T0214	T0214	T0214			
		43UW				D0214	D0214				E0414					T0214	T0214				P0414
		7M3W							E0419	E0419									P0419	P0419	
		103W							E0419	E0419									P0419	P0419	
		7M3UW							F0119	F0119									Q0119	Q0119	
103UW							F0119	F0119									Q0119	Q0119			
J4	HG-KR	053									L0308	L0308	L0308			N0308					
		13									L0308	L0308	L0308			N0308					
		23				C0514	C0514	C0514							N0514	N0514	N0514				
		43				C0514	C0514				E0214				N0514	N0514				P0214	
		73							E0419	E0419								P0419	P0419		
	HG-MR	053										L0308	L0308	L0308			N0308				
		13										L0308	L0308	L0308			N0308				
		23				C0514	C0514	C0514							N0514	N0514	N0514				
		43				C0514	C0514				E0214				N0514	N0514				P0214	
		73							E0419	E0419								P0419	P0419		

■の型式は減速機加速時ピークトルクを超えないようご注意ください。
Please be careful so that the peak torque during acceleration of the reducer is not exceeded about the motor mounting Number in gray colour.

モータ型式		PSR型式・減速比																			
		入力軸：キー穴(標準)									入力軸：クランプ										
		PSR70			PSR110			PSR135			PSR70			PSR110			PSR135				
		19	39	49	19	39	59	19	39	59	19	39	49	19	39	59	19	39	59		
Σ-X	SGMXJ	A5A	A0308	A0308	A0308							L0308	L0308	L0308							
		01A	A0308	A0308	A0308			C0308				L0308	L0308	L0308			N0308				
		C2A	A0308	A0308	A0308			C0308				L0308	L0308	L0308			N0308				
		02A				C0514	C0514	C0514								N0514	N0514	N0514			
		04A				C0514	C0514				E0214					N0514	N0514			P0214	
		06A							E0214	E0214	E0214								P0214	P0214	P0214
		08A							E0419	E0419									P0419	P0419	
	SGMXA	A5A	A0308	A0308	A0308							L0308	L0308	L0308							
		01A	A0308	A0308	A0308			C0308				L0308	L0308	L0308			N0308				
		C2A	A0308	A0308	A0308			C0308				L0308	L0308	L0308			N0308				
		02A				C0514	C0514	C0514								N0514	N0514	N0514			
		04A				C0514	C0514				E0214					N0514	N0514			P0214	
		06A							E0214	E0214	E0214								P0214	P0214	P0214
		08A							E0419	E0419									P0419	P0419	
Σ-7	SGM7J	A5A	A0308	A0308	A0308							L0308	L0308	L0308							
		01A	A0308	A0308	A0308			C0308				L0308	L0308	L0308			N0308				
		C2A	A0308	A0308	A0308			C0308				L0308	L0308	L0308			N0308				
		02A				C0514	C0514	C0514								N0514	N0514	N0514			
		04A				C0514	C0514				E0214					N0514	N0514			P0214	
		06A							E0214	E0214	E0214								P0214	P0214	P0214
		08A							E0419	E0419									P0419	P0419	
	SGM7A	A5A	A0308	A0308	A0308							L0308	L0308	L0308							
		01A	A0308	A0308	A0308			C0308				L0308	L0308	L0308			N0308				
		C2A	A0308	A0308	A0308			C0308				L0308	L0308	L0308			N0308				
		02A				C0514	C0514	C0514								N0514	N0514	N0514			
		04A				C0514	C0514				E0214					N0514	N0514			P0214	
		06A							E0214	E0214	E0214								P0214	P0214	P0214
		08A							E0419	E0419									P0419	P0419	
	SGM7P	01A	B0208	B0208	B0208			C0508				M0208	M0208	M0208			N0508				
		02A				D0214	D0214	D0214								T0214	T0214	T0214			
		04A				D0214	D0214				E0414					T0214	T0214			P0414	
	SGM7G	03A							F0116	F0116	F0116								Q0116	Q0116	Q0116
		05A							F0116	F0116									Q0116	Q0116	

※オイルシール付は除きます
*Excluding motor models which set the shaft part with the oil seal.

モータ・減速機対応表 Motor/Reducer Corresponding Table

富士電機 Fuji Electric

■の型式は減速機加速時ピークトルクを超えないようにご注意ください。
Please be careful so that the peak torque during acceleration of the reducer is not exceeded about the motor mounting Number in gray colour.

モータ型式		PSR型式・減速比																	
		入力軸：キー穴(標準)									入力軸：クランプ								
		PSR70			PSR110			PSR135			PSR70			PSR110			PSR135		
		19	39	49	19	39	59	19	39	59	19	39	49	19	39	59	19	39	59
GYS	101	A0308	A0308	A0308			C0308				L0308	L0308	L0308			N0308			
	201				C0514	C0514	C0514							N0514	N0514	N0514			
	401				C0514	C0514				E0214				N0514	N0514				P0214
	751							E0416	E0416								P0416	P0416	
GYC	101	B0208	B0208	B0208			C0508				M0208	M0208	M0208			N0508			
	201				D0214	D0214	D0214							T0214	T0214	T0214			
	401				D0214	D0214				E0414				T0214	T0214				P0414
	751							F0216	F0216								Q0216	Q0216	

Panasonic

■の型式は減速機加速時ピークトルクを超えないようにご注意ください。
Please be careful so that the peak torque during acceleration of the reducer is not exceeded about the motor mounting Number in gray colour.

モータ型式		PSR型式・減速比																		
		入力軸：キー穴(標準)									入力軸：クランプ									
		PSR70			PSR110			PSR135			PSR70			PSR110			PSR135			
		19	39	49	19	39	59	19	39	59	19	39	49	19	39	59	19	39	59	
A6	MSMF	5A	A0208	A0208	A0208			C0208				L0208	L0208	L0208			N0208			
		01	A0208	A0208	A0208			C0208				L0208	L0208	L0208			N0208			
		02				C0411	C0411	C0411							N0411	N0411	N0411			
		04				C0414	C0414				E0114				N0414	N0414				P0114
		08							E0319	E0319								P0319	P0319	
		09							E0319	E0319								P0319	P0319	
	MQMF	01	B0108	B0108	B0108			C0408				M0108	M0108	M0108			N0408			
		02				D0111	D0111	D0111							T0111	T0111	T0111			
		04				D0114	D0114				E0314				T0114	T0114				P0314
	MHMF	5A	A0308	A0308	A0308			C0308				L0308	L0308	L0308			N0308			
		01	A0308	A0308	A0308			C0308				L0308	L0308	L0308			N0308			
		02				C0411	C0411	C0411							N0411	N0411	N0411			
04					C0414	C0414				E0114				N0414	N0414				P0114	
08								E0319	E0319								P0319	P0319		
09								E0319	E0319								P0319	P0319		
A5	MSME	5A	A0208	A0208	A0208			C0208				L0208	L0208	L0208			N0208			
		01	A0208	A0208	A0208			C0208				L0208	L0208	L0208			N0208			
		02				C0411	C0411	C0411							N0411	N0411	N0411			
		04				C0414	C0414				E0114				N0414	N0414				P0114
		08							E0319	E0319								P0319	P0319	
		10							F0219	F0219										
	MSMD	5A	A0208	A0208	A0208			C0208				L0208	L0208	L0208			N0208			
		01	A0208	A0208	A0208			C0208				L0208	L0208	L0208			N0208			
		02				C0411	C0411	C0411							N0411	N0411	N0411			
		04				C0414	C0414				E0114				N0414	N0414				P0114
		08							E0319	E0319								P0319	P0319	
		MHMD	02				C0411	C0411	C0411							N0411	N0411	N0411		
04					C0414	C0414				E0114				N0414	N0414				P0114	
08								E0319	E0319								P0319	P0319		
08								E0319	E0319								P0319	P0319		

※オイルシール付は除きます

*Excluding motor models which set the shaft part with the oil seal.

■の型式は減速機加速時ピークトルクを超えないようにご注意ください。
Please be careful so that the peak torque during acceleration of the reducer is not exceeded about the motor mounting Number in gray colour.

モータ型式			PSR型式・減速比																	
			入力軸：キー穴(標準)									入力軸：クランプ								
			PSR70			PSR110			PSR135			PSR70			PSR110			PSR135		
			19	39	49	19	39	59	19	39	59	19	39	49	19	39	59	19	39	59
αSTEP	AZM	46										V0106	V0106	V0106						
		48	H0108	H0108	H0108							V0108	V0108	V0108						
		66				J0110	J0110	J0110							W0110	W0110	W0110			
		69				J0110	J0110	J0110							W0110	W0110	W0110			
		98				K0114	K0114	K0114							Y0114	Y0114	Y0114			
		911				K0114	K0114	K0114							Y0114	Y0114	Y0114			
	AR	46										V0106	V0106	V0106						
		66													W0110	W0110	W0110			
		98													Y0114	Y0114	Y0114			

仕様・寸法表

Specifications / Dimensional Tables

PSL

Lightweight model

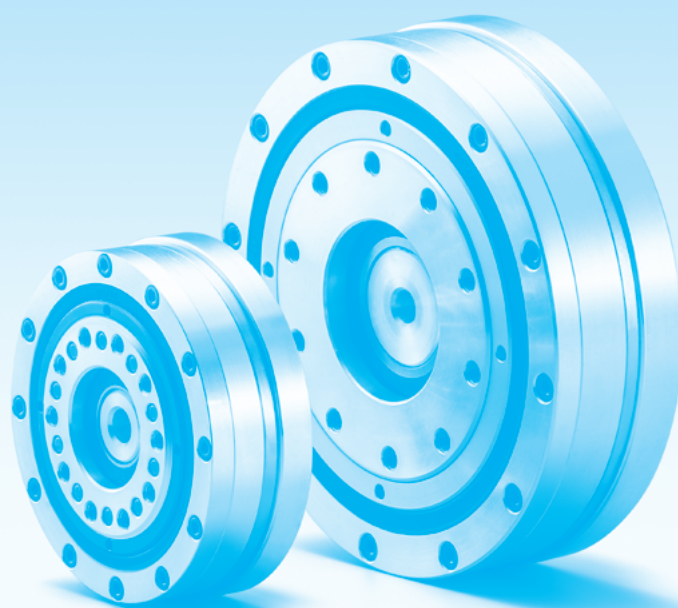

PSL仕様 PSL Specifications

型 式 Model	PSL70			PSL110			
	減速比 Reduction ratio	19	39	49	19	39	59
入力軸に対する出力軸の回転方向 Rotational direction of output axis to input axis	逆方向 Reverse direction			逆方向 Reverse direction			
許容定格トルク Allowable rated torque	N・m	12	20	20	26	52	52
加速時ピークトルク Accelerating peak torque	N・m	26	42	42	52	104	104
瞬時最大トルク Maximum instantaneous torque	N・m	48	78	78	96	195	195
許容平均入力回転数 Allowable average rotational speed	rpm	3000			2000		
最高入力回転数 Maximum rotational speed	rpm	4500			4500		
バックラッシュ Backlash	arcmin	4			3		
推奨モータ容量 Recommended motor capacity	W	100			200・400		
入力軸換算慣性モーメント Input axis equivalent inertia moment	$\times 10^{-4} \text{kg} \cdot \text{m}^2$	0.041	0.040	0.040	0.256	0.247	0.246
入力軸穴径 Input axis hole diameter	mm	6・8			8・10・11・14		
質量(モータアタッチメントなし) Mass (without motor attachment)	kg	0.42			1.4		

連続回転にて使用される場合は弊社にご相談ください。
When you intend to use in continuous revolution, please contact to us.

型式表示 Model Indication

● PSL型式 Model PSL

PSL 110 F C A - 59 - N01 08

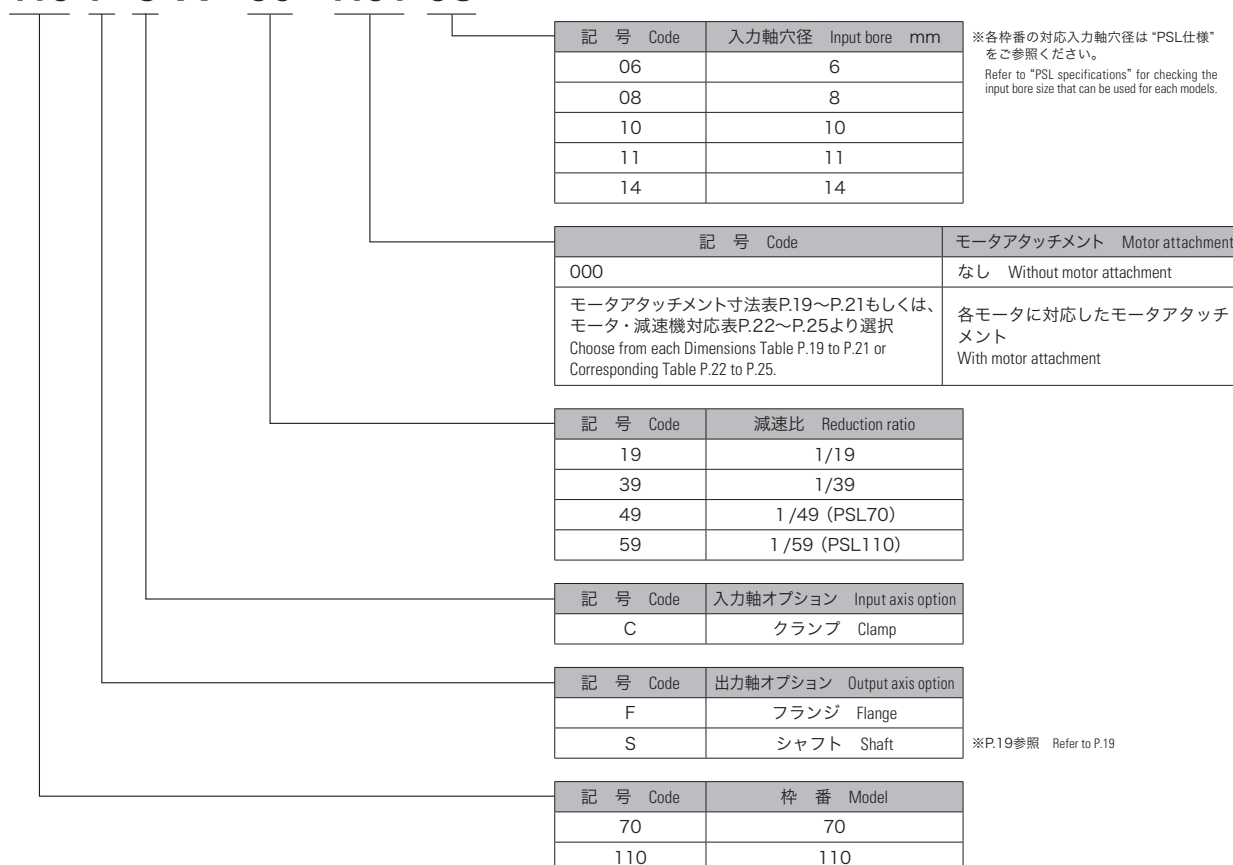

仕様・型式・外形図 Specifications, Models, Outline Drawings

外形寸法図 Outline dimensional drawings

● PSL70FCA-□□-000□□

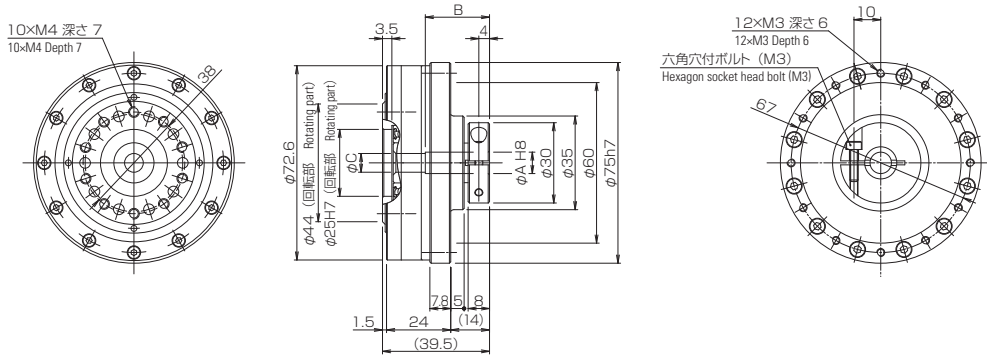

寸法表 Dimensional table

型式 Model	A	B	C
PSL70FCA-□□-00006	6	17.5	5
PSL70FCA-□□-00008	8	21.5	7

● PSL110FCA-□□-000□□

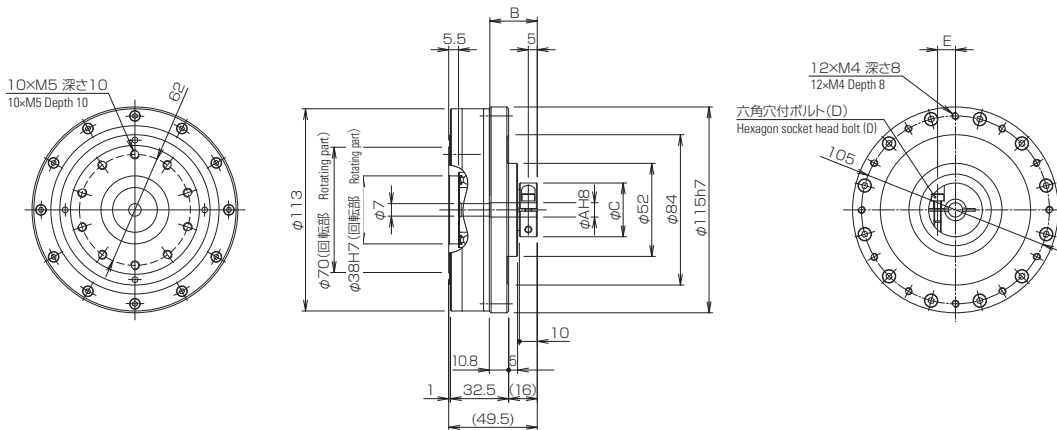

寸法表 Dimensional table

型式 Model	A	B	C	D	E
PSL110FCA-□□-00008	8	21.5	30	M4	10
PSL110FCA-□□-00010	10	21.5	40	M5	14
PSL110FCA-□□-00011	11	26.5	40	M5	14
PSL110FCA-□□-00014	14	34.5	40	M5	14

オプション 入力と出力の形態に設計の自由度があります。
Option Both the input mode and the output mode have the degree of freedom in design.

●出力軸オプションS(シャフト) **Output axis option S (shaft)**

シャフトの材質はS45Cです。
 The material of the output shaft is S45C.

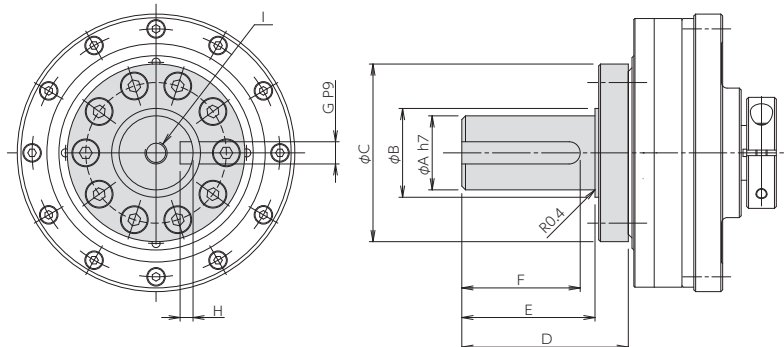

寸法表 **Dimension table**

型式 Model	A	B	C	D	E	F	G	H	I	質量 kg Mass
PSL70SCA-□□-□□□□□□	20	24	48	45	36	32	6	3.5 ^{+0.1} ₀	M6 深さ12 M6 Depth 12	0.2
PSL110SCA-□□-□□□□□□	30	34	74	68	58	50	8	4 ^{+0.2} ₀	M8 深さ16 M8 Depth 16	0.6

●モータアタッチメント **Motor attachment**

モータアタッチメントの材質はアルミ合金(A2017)です。
 The material of the motor attachment is aluminum alloy (A2017).

記号 **Code** : L□□・N□□

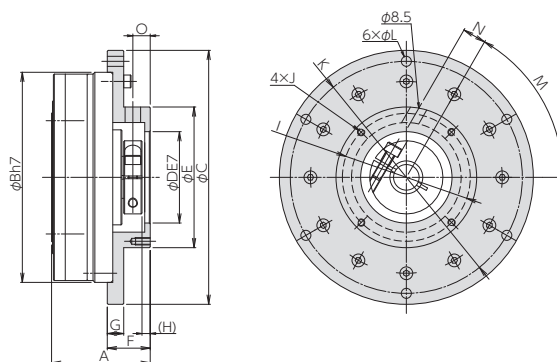

寸法表 **Dimension table**

型式 Model	記号 Code	A	B	C	D	E	F	G	H	I	J	K	L	M	N	O	質量 kg Mass
PSL70	L01	44	75	94	22	56	21	8	4.5	48	M3 深さ6 M3 Depth 6	86	4.5	90°	9	8	0.16
	L02	44	75	94	30	56	21	8	4.5	45	M3 深さ6 M3 Depth 6	86	4.5	90°	9	8	0.16
	L03	44	75	94	30	56	21	8	4.5	46	M4 深さ8 M4 Depth 8	86	4.5	90°	9	8	0.16
PSL110	N01	54	115	139	22	77	23.5	9	4.5	48	M3 深さ6 M3 Depth 6	127	5.5	60°	13	9.5	0.40
	N02	54	115	139	30	77	23.5	9	4.5	45	M3 深さ6 M3 Depth 6	127	5.5	60°	13	9.5	0.40
	N03	54	115	139	30	77	23.5	9	4.5	46	M4 深さ8 M4 Depth 8	127	5.5	60°	13	9.5	0.40
	N04	54	115	139	50	77	23.5	9	4.5	70	M4 深さ8 M4 Depth 8	127	5.5	60°	13	9.5	0.34
	N05	54	115	139	50	77	23.5	9	4.5	70	M5 深さ10 M5 Depth 10	127	5.5	60°	13	9.5	0.34

オプション 駆動モータを取り付けるためのモータアタッチメントです。モーターメーカー及び型式に合わせてお選び下さい。
Option These options are motor attachments for mounting drive motors. Select one according to the motor manufacturer and model.

●モータアタッチメント **Motor attachment**

記号 **Code** : M□□・T□□

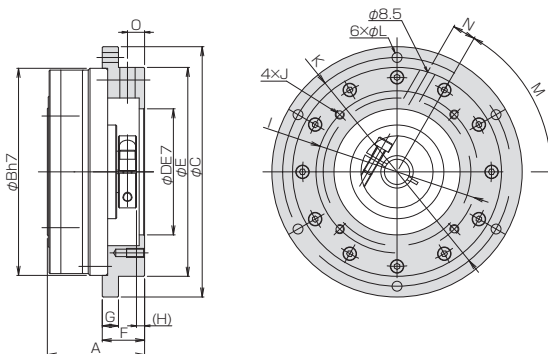

寸法表 **Dimensional table**

型式 Model	記号 Code	A	B	C	D	E	F	G	H	I	J	K	L	M	N	O	質量 kg Mass
PSL70	M01	44	75	94	50	77	21	8	4.5	70	M4 深さ8 M4 Depth 8	86	4.5	90°	9	8	0.16
	M02	44	75	94	50	77	21	8	4.5	70	M5 深さ10 M5 Depth 10	86	4.5	90°	9	8	0.16
PSL110	T01	54	115	139	70	116	23.5	9	4.5	90	M5 深さ10 M5 Depth 10	127	5.5	60°	13	9.5	0.42
	T02	54	115	139	70	116	23.5	9	4.5	90	M6 深さ12 M6 Depth 12	127	5.5	60°	13	9.5	0.42

記号 **Code** : W01

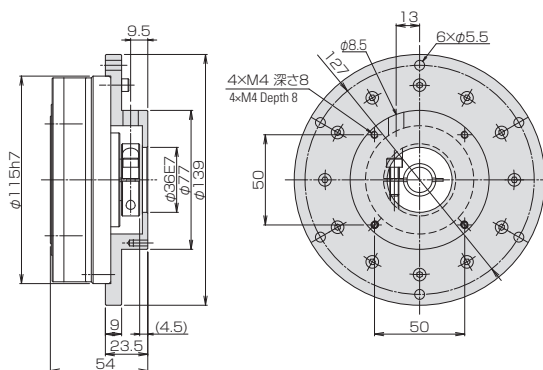

寸法表 **Dimensional table**

型式 Model	記号 Code	質量 kg Mass
PSL110	W01	0.34

● モータアタッチメント Motor attachment

記号 Code : V□□・Y□□

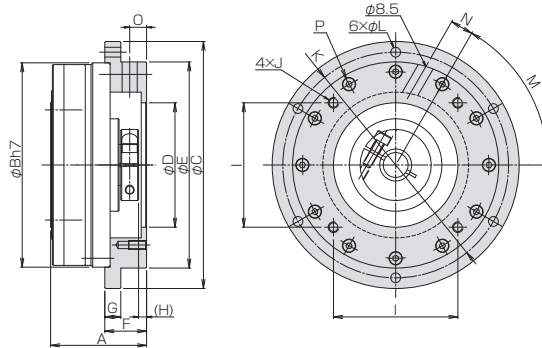

寸法表 Dimensional table

型式 Model	記号 Code	A	B	C	D	E	F	G	H	I	J	K	L	M	N	O	P	質量 kg Mass
PSL70	V01	44	75	94	22H7	77	21	8	4.5	31	φ3.5	86	4.5	90°	9	8	M3	0.18
PSL110	Y01	54	115	139	60E7	116	23.5	9	4.5	70	M6 深さ12 M6 Depth 12	127	5.5	60°	13	9.5	—	0.44

※モータアタッチメント：V01はモータ取付後、付属の六角穴付ボルト（M3）で減速機に固定してください。
After combined with your motor and Motor attachment No.V01, please combine it to Reducer by hexagon socket head bolt (M3) we enclosed.

モータ・減速機対応表 Motor/Reducer Corresponding Table

モータ・減速機対応表は簡易表です。必ず型式選定計算を行ってください。グレー表示の型式は、減速機加速時ピークトルクを超えないようにご使用ください。掲載されていないモータ型式については弊社にお問い合わせください。

Since the Motor and Reduction Ratio Correspondence Table is a simplified presentation, be sure to make a model selecting calculation. Please use so that the peak torque during acceleration of the reducer is not exceeded about the motor mounting Number in gray colour. For any motor model not listed here, please contact us.

三菱電機 Mitsubishi Electric

■の型式は減速機加速時ピークトルクを超えないようにご注意ください。

Please be careful so that the peak torque during acceleration of the reducer is not exceeded about the motor mounting Number in gray colour.

モータ型式			PSL型式・減速比					
			PSL70			PSL110		
			19	39	49	19	39	59
J5	HK-KT	053W	L0308	L0308	L0308			N0308
		13W	L0308	L0308	L0308			N0308
		1M3W	L0308	L0308				N0308
		13UW	M0208	M0208	M0208			N0508
		23W				N0514	N0514	N0514
		43W				N0514	N0514	
		23UW				T0214	T0214	T0214
		43UW				T0214	T0214	
J4	HG-KR	053	L0308	L0308	L0308			N0308
		13	L0308	L0308	L0308			N0308
		23				N0514	N0514	N0514
		43				N0514	N0514	
	HG-MR	053	L0308	L0308	L0308			N0308
		13	L0308	L0308	L0308			N0308
		23				N0514	N0514	N0514
		43				N0514	N0514	

モータ型式			PSL型式・減速比					
			PSL70			PSL110		
			19	39	49	19	39	59
Σ-X	SGMXJ	A5A	L0308	L0308	L0308			
		01A	L0308	L0308	L0308			N0308
		C2A	L0308	L0308	L0308			N0308
		02A				N0514	N0514	N0514
		04A				N0514	N0514	
	SGMXA	A5A	L0308	L0308	L0308			
		01A	L0308	L0308	L0308			N0308
		C2A	L0308	L0308	L0308			N0308
		02A				N0514	N0514	N0514
		04A				N0514	N0514	
Σ-7	SGM7J	A5A	L0308	L0308	L0308			
		01A	L0308	L0308	L0308			N0308
		C2A	L0308	L0308	L0308			N0308
		02A				N0514	N0514	N0514
		04A				N0514	N0514	
	SGM7A	A5A	L0308	L0308	L0308			
		01A	L0308	L0308	L0308			N0308
		C2A	L0308	L0308	L0308			N0308
		02A				N0514	N0514	N0514
		04A				N0514	N0514	
	SGM7P	01A	M0208	M0208	M0208			N0508
		02A				T0214	T0214	T0214
		04A				T0214	T0214	

※オイルシール付は除きます
*Excluding motor models which set the shaft part with the oil seal.

モータ・減速機対応表 Motor/Reducer Corresponding Table

富士電機 Fuji Electric

■の型式は減速機加速時ピークトルクを超えないようにご注意ください。
Please be careful so that the peak torque during acceleration of the reducer is not exceeded about the motor mounting Number in gray colour.

モータ型式		PSL型式・減速比					
		PSL70			PSL110		
		19	39	49	19	39	59
GYS	101	L0308	L0308	L0308			N0308
	201				N0514	N0514	N0514
	401				N0514	N0514	
GYC	101	M0208	M0208	M0208			N0508
	201				T0214	T0214	T0214
	401				T0214	T0214	

Panasonic

■の型式は減速機加速時ピークトルクを超えないようにご注意ください。
Please be careful so that the peak torque during acceleration of the reducer is not exceeded about the motor mounting Number in gray colour.

モータ型式			PSL型式・減速比						
			PSL70			PSL110			
			19	39	49	19	39	59	
A6	MSMF	5A	L0208	L0208	L0208			N0208	
		01	L0208	L0208	L0208			N0208	
		02				N0411	N0411	N0411	
		04				N0414	N0414		
	MQMF	01	M0108	M0108	M0108			N0408	
		02				T0111	T0111	T0111	
		04				T0114	T0114		
	MHMF	5A	L0308	L0308	L0308			N0308	
		01	L0308	L0308	L0308			N0308	
		02				N0411	N0411	N0411	
		04				N0414	N0414		
	A5	MSME	5A	L0208	L0208	L0208			N0208
01			L0208	L0208	L0208			N0208	
02						N0411	N0411	N0411	
04						N0414	N0414		
MSMD		5A	L0208	L0208	L0208			N0208	
		01	L0208	L0208	L0208			N0208	
		02				N0411	N0411	N0411	
		04				N0414	N0414		
MHMD		02				N0411	N0411	N0411	
		04				N0414	N0414		
E		MUMA	5A	L0108	L0108	L0108			N0108
			01	L0108	L0108	L0108			N0108
	02					N0411	N0411	N0411	
	04					N0414	N0414		

※オイルシール付は除きます
*Excluding motor models which set the shaft part with the oil seal.

■の型式は減速機加速時ピークトルクを超えないようにご注意ください。
Please be careful so that the peak torque during acceleration of the reducer is not exceeded about the motor mounting Number in gray colour.

モータ型式			PSL型式・減速比					
			PSL70			PSL110		
			19	39	49	19	39	59
αSTEP	AZM	46	V0106	V0106	V0106			
		48	V0108	V0108	V0108			
		66				W0110	W0110	W0110
		69				W0110	W0110	W0110
		98				Y0114	Y0114	Y0114
		911				Y0114	Y0114	Y0114
	AR	46	V0106	V0106	V0106			
		66				W0110	W0110	W0110
		98				Y0114	Y0114	Y0114

PSR/PSL Series
技術資料

Technical Data

型式選定フローチャート Model Selection Flow Chart

使用条件から型式を選定します。

The model No. of the ball reduction gear is selected according to the operating conditions.

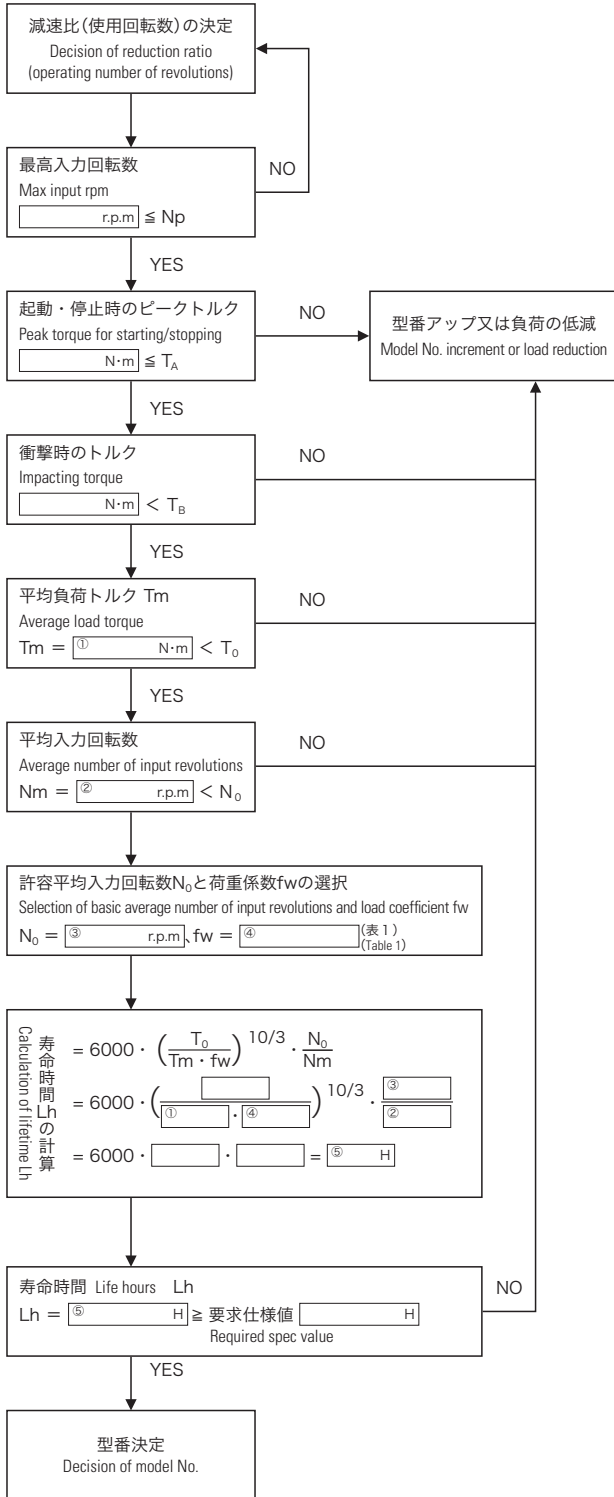

- Np : 最高入力回転数 (rpm)
Max input rpm
- TA : 加速時ピークトルク (N · m)
Acceleration peak torque
- T0 : 許容定格トルク (N · m)
Allowable rated torque
- TB : 瞬時最大トルク (N · m)
Max. instantaneous torque
- N0 : 許容平均入力回転数 (rpm)
Acceleration peak torque

表 1 荷重係数 Table 1 Load coefficient

運転条件 Operating conditions	fw
衝撃のない円滑運転のとき In smooth operation with no impacts	1.0~1.2
普通の運転のとき In normal operation	1.2~1.5
衝撃・振動を伴う運転のとき In operation with impacts and vibrations	1.5~3.0

参考計算式 Reference calculation formula

速度パターン
Velocity pattern

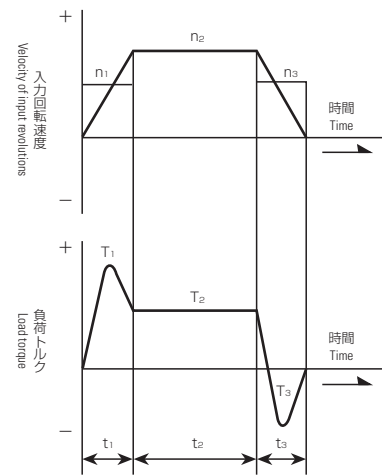

負荷パターン
Load pattern

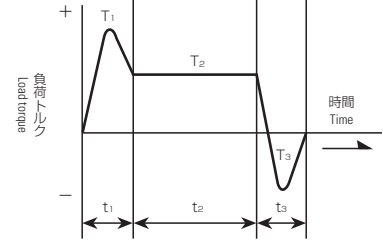

平均負荷トルク Average load torque

$$T_m = \sqrt[10/3]{\frac{n_1 t_1 T_1^{10/3} + n_2 t_2 T_2^{10/3} + n_3 t_3 T_3^{10/3}}{n_1 t_1 + n_2 t_2 + n_3 t_3}}$$

平均入力回転数 Average number of input revolutions

$$Nm = \frac{t_1 n_1 + t_2 n_2 + t_3 n_3}{t_1 + t_2 + t_3}$$

表 2 運転条件 Table 2 Operating conditions

項目 Item	起動時 Starting	定常時 Steady operation	停止時 Stoppage
負荷トルク Load torque N · m	T ₁	T ₂	T ₃
回転数 Number of revolutions rpm	n ₁ (=0.5 n ₂)	n ₂	n ₃ (=0.5 n ₂)
時間 Time sec	t ₁	t ₂	t ₃

クロスローラベアリングの計算 Calculation of Cross-Roller Bearing

最大負荷モーメント荷重の計算(Mmax) Calculation of maximum load moment load (Mmax)

$$M_{max} = Fr_{max} (L_r + L_c / 1000) + Fa_{max} \cdot L_a$$

- Fr max : 最大ラジアル荷重 Maximum radial load (N)
- Fa max : 最大アキシャル荷重 Maximum axial load (N)
- Lr : ラジアル荷重位置 Radial load position (m)
- La : アキシャル荷重位置 Axial load position (m)

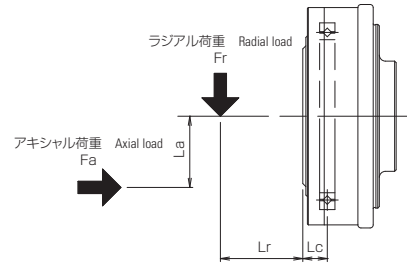

最大負荷モーメント荷重が許容モーメント荷重以下であることを確認します。
Check whether the maximum load moment load is equal to or less than the allowable moment load.

$$M_{max} \leq Mc$$

(許容モーメント荷重は以下の表を参照のこと)
(For the allowable moment load, refer to the following table.)

型式 Model	減速比 Reduction ratio	オフセット量 Offset amount Lc (mm)	許容モーメント荷重 Allowable moment load Mc (N・m)	許容ラジアル荷重 Allowable radial load (N)	許容アキシャル荷重 Allowable axial load (N)
PSR70 PSL70	19	8	12	450	670
	39		15	560	830
	49		16	600	890
PSR110 PSL110	19	9.5	52	1210	1800
	39		65	1500	2230
	59		74	1700	2530
PSR135	19	12.5	72	1350	2010
	39		90	1680	2500
	59		102	1900	2830

許容ラジアル荷重、許容アキシャル荷重はクロスローラベアリングに純粋なラジアル荷重又はアキシャル荷重のみどちらかがかかる場合に減速機寿命時間を満たす値です (ラジアル荷重: Lr + Lc = 0 アキシャル荷重: La = 0)
The allowable radial load and the allowable axial load are the values that satisfy the lifetime of the reducer when either net radial load or net axial load is imposed on the cross-roller bearing. (Radial load: Lr + Lc = 0, Axial load: La = 0)

平均荷重の計算式 Calculation formulas of average load

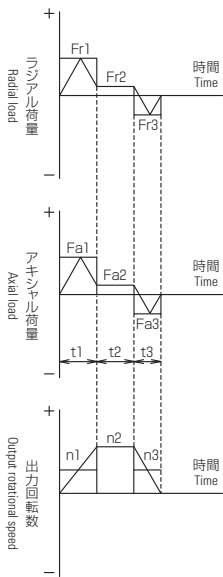

平均ラジアル荷重 Fra (N)

Average radial load

$$Fra = \sqrt[10/3]{\frac{n1t1(|Fr1|)^{10/3} + n2t2(|Fr2|)^{10/3} + \dots + nntn(|Frn|)^{10/3}}{n1t1 + n2t2 + \dots + nntn}}$$

平均アキシャル荷重 Faa (N)

Average axial load

$$Faa = \sqrt[10/3]{\frac{n1t1(|Fa1|)^{10/3} + n2t2(|Fa2|)^{10/3} + \dots + nntn(|Fan|)^{10/3}}{n1t1 + n2t2 + \dots + nntn}}$$

平均出力回転数 Na (rpm)

Average output rotational speed

$$Na = \frac{n1t1 + n2t2 + \dots + nntn}{t1 + t2 + \dots + tn}$$

平均モーメント荷重 Ma (N・m)

Average moment load

$$Ma = Fra(Lr + Lc) + Faa \cdot La$$

ラジアル係数(X)・アキシャル係数(Y)の計算式 Calculation formulas of radial coefficient and axial coefficient

区分 Classification	ラジアル係数(X) Radial coefficient	アキシャル係数(Y) Axial coefficient
$\frac{F_{aa}}{F_{ra} + 2Ma/D_{pw}} \leq 1.5$	1	0.45
$\frac{F_{aa}}{F_{ra} + 2Ma/D_{pw}} > 1.5$	0.67	0.67

型式 Model	基本動定格荷重 Basic kinetic rated torque C (N)	ローラのピッチ円直径 Roller pitch circle diameter Dpw (m)
PSR70 PSL70	1520	0.05475
PSR110 PSL110	4080	0.0871
PSR135	4560	0.1071

荷重係数 Load coefficient (fw)

荷重状態 Load state	fw
衝撃のない円滑運転のとき In smooth operation with no impacts	1.0~1.2
普通の運転のとき In normal operation	1.2~1.5
衝撃・振動を伴う運転のとき In operation with impacts and vibrations	1.5~3.0

寿命計算 Life Calculation (Lh)

クロスローラベアリングの寿命は次式により求めます。
For the cross roller bearing, calculate the life hours by using the following formula

$$Lh = \left(\frac{10^6}{60 \cdot N_a} \right) \cdot \left(\frac{C}{f_w \cdot P_c} \right)^{10/3}$$

動等価ラジアル荷重 Kinetic Equivalent Radial Load (Pc)

$$P_c = X \cdot \left(F_{ra} + \frac{2Ma}{D_{pw}} \right) + Y \cdot F_{aa}$$

技術データ Technical Data

● 角度伝達精度 Angular transmission accuracy

角度伝達精度は、入力軸側に、任意の回転角(θ₁)を与えた時の出力軸の理論上回転する回転角度(θ₂)と実際に回転した角度(θ'₂)との差をいい、出力軸1回転で生じる最大差を角度伝達精度(θ_{er})と表します。

The angular transmission error at the time when an arbitrary rotation angle (θ₁) is applied to the input axis side refers to the difference between the rotation angle (θ₂) of the output axis formed due to theoretical rotation and the rotation angle (θ'₂) formed due to actual rotation. The maximum difference caused by the rotation of the output axis by one turn is expressed as the angular transmission accuracy (θ_{er}).

$$\theta_{er} = \theta'_2 - \theta_2 = \theta'_2 - \theta_1 / R \quad (R : \text{減速比 Reduction ratio})$$

型式 Model	角度伝達精度 Angular transmission accuracy arcmin
PSR70・PSL70	5
PSR110・PSL110	4
PSR135	3

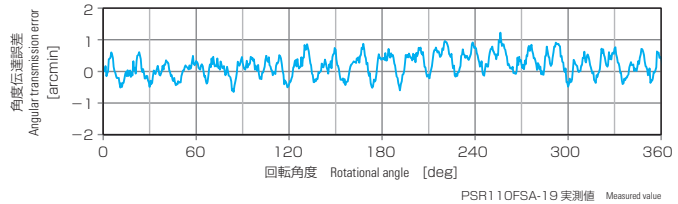

● 剛性 Rigidity

入力軸を固定し、出力軸にトルクを加えると、出力軸はトルクにほぼ比例したねじれを生じ、ヒステリシスカーブを描きます。これを定量的に表現する為に、定格トルクの3%と100%の点をつなぐ折れ線グラフを考え、

- ・バネ定数 = b/a
- ・ロストモーション：定格トルクの±3%でのヒステリシスカーブの中間点のねじれ角と定義します。

When torque is applied to the output axis while the input axis being fixed, the output axis produces a torsion in nearly proportion to the applied torque as shown in the below a hysteresis curve. In order to express the torque and torsion quantitatively, a sequential line graph is plotted by connecting the points 3% and 100% of the rated torque, and the spring constant and the lost motion are defined as follows:

- ・ Spring constant = b/a
- ・ Lost motion = Torsion angle at the midpoint of the hysteresis curve at ±3% of the rated torque

型式 Model	速比 Speed ratio	ロストモーション Lost motion arcmin	バネ定数 b/a Spring constant b/a × 10 ⁴ N・m/rad
PSR70	19	4	0.6
	49		0.9
PSR110	19	3	1.7
	59		3.3
PSR135	19	3	5.2
	59		11.0
PSL70	19	4	0.6
	49		0.9
PSL110	19	3	1.7
	59		3.3

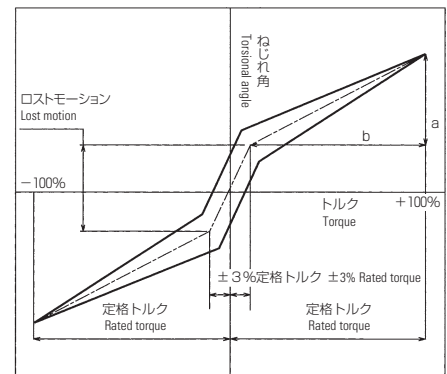

(注)バネ定数値は、製品サンプルでの平均値を示します。
Note : The spring constant value indicates the average value of product samples.

● 効 率 Efficiency

各型式の負荷率(定格トルクに対する負荷の割合)に対する効率の値を示します。

＜測定条件＞周囲温度25℃、回転数3000rpm(PSL110のみ2000rpm)

The graphs show the ball reducer efficiency at each load factor (the ratio of the rated torque to the load) per the each rotation of the input shaft for each model. (Measurement condition) the ambient temperature 25℃, Rotational speed 3000 rpm, only for PSL110 is measured at 2000 rpm.

PSR70

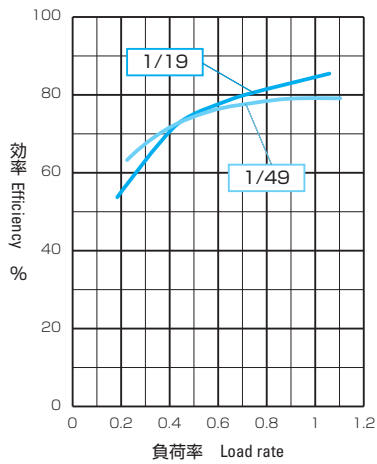

PSR110

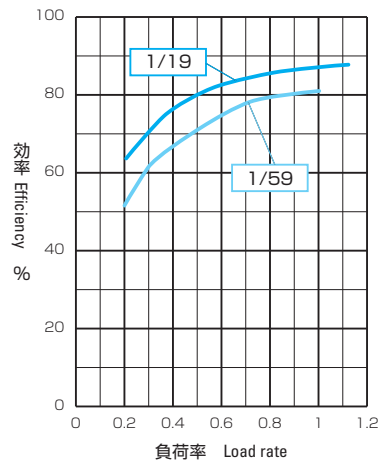

PSR135

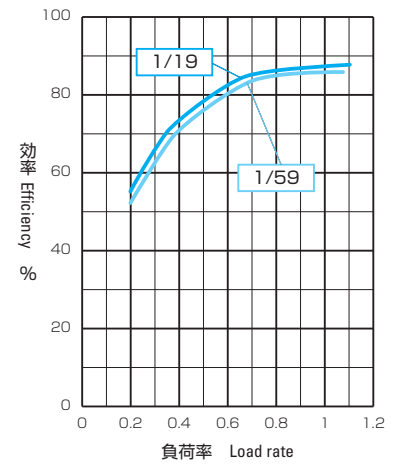

PSL70

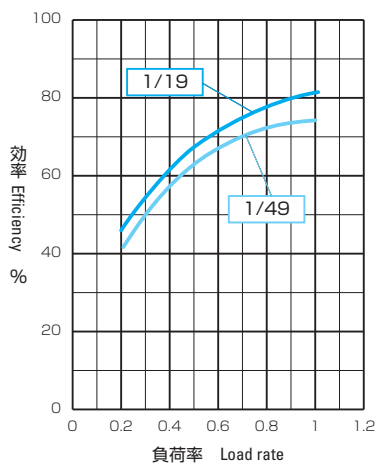

PSL110

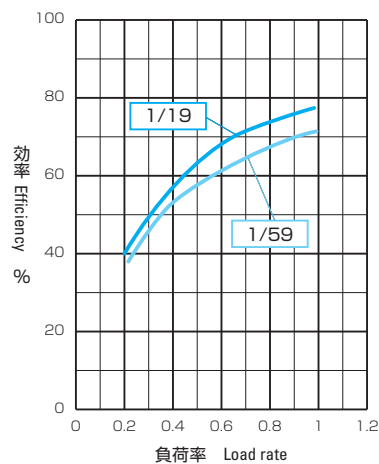

(注)効率値は、製品サンプルでの平均値を示します。 Note: The efficiency value indicates the average value of product samples.

ノンバックラッシュTCG・SFPシリーズ Non-backlash TCG・SFP Series

TCG・SFP

Trochoid Cam Gear

ボールねじ・ラック&ピニオンを超えた直線・曲線駆動システムの提案

Introduction of linear and curvilinear drive system superior to ball-type screw and rack & pinion.

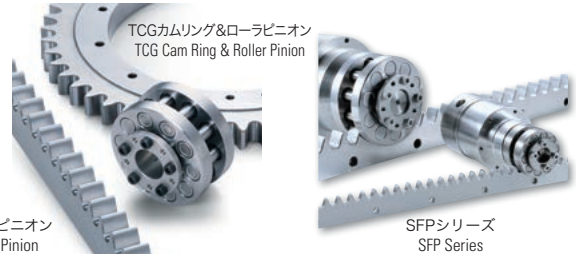

TCGカムラック&ローラピニオン
TCG Cam Rack & Roller Pinion

SFPシリーズ
SFP Series

ノンバックラッシュボール減速機シリーズ Non-backlash Ball Reducer Series

BR

Ball Reducer

ボールにより軽快高効率・高精度を実現したノンバックラッシュ減速機

Non-backlash reducer with smoothness, high efficiency and high precision realized by the employment of balls



同心軸薄型ボール減速機 JFRシリーズ
Just-fit Ball Reducer JFR Series

同心軸ボール減速機 BRシリーズ
Coaxial-shaft Type Ball Reducer BR Series

パールデックスシリーズ PearlDex Series

PDW

Pearl Index System

高精度でありながら低価格を実現したインデックス

Index Mechanism With High Accuracy At Low Price



パールデックス PDWシリーズ
PearlDex PDW Series

インデックスシリーズ Index Series

MINIDEX・MINITABLE

Indexing Actuator

複合動作をユニット化、シンプル構造で使いやすいエア・アクチュエータ

The compound operation is made a unit. Air actuator that is easy to use because of simple structure.



ミニテーブル MTシリーズ
Minitable MT Series

ミニデックス MDFシリーズ
Minidex MDF Series

PSR/PSL series 適用上のご注意



●本製品の最終使用者が軍事関係であったり、用途が兵器などの製造用である場合には、「外国為替管理法」の定める輸出規制の対象となる場合がありますので、輸出される際には十分な審査及び必要な輸出手続きをお取り下さい。●本品は、人命にかかわるような状況下で使用される機器などに使用される目的として、設計・製造されたものではありません。●本品を特殊用途(航空宇宙用・原子力関連・乗用移動用・医療機器など)での使用をご検討の際は、弊社までご一報下さい。●本品は厳重な品質管理のもとに製造しておりますが、万一本品が故障することにより人命にかかわるような重要な設備、重大な損失の発生が予想される設備への適用に際しては、重大事故にならないよう安全装置を設置して下さい。●本製品を特殊環境(クリーンルーム、食品など)に使用される場合は、あらかじめ当社代理店または最寄りの営業所へご連絡下さい。●油分の漏れには構造上配慮しておりますが、完全に密閉しているわけではありません。ご使用用途、運転条件によっては、僅かに漏れが発生することがあります。問題がある場合は外部でシール性を確保して下さい。

Precautions for using PSR/PSL Series



● If the user of the product is a military interest or if the product is to be used in the manufacture of weapons, the product may be subject to export regulations prescribed in the Foreign Trade Control Act. Confirm these conditions before exporting the product and take the necessary steps. ● Our products are not designed and manufactured to be used for the machines or equipment which may affect people's lives. ● Please contact with Kamo Seiko or local distributor if the products are used for the special applications such (aero-space, atomic power, vehicle, medical and etc.). ● Although our product has been manufactured under our strict quality control, it is advisable to provide a safety device when our product is applied to a perilous use. This is to avoid any accident that could cause serious damage to people or property in case of a problem with our product. ● When this product is used in a special environment (clean room, food handling facility, etc.), please contact with Kamo Seiko or local distributor. ● Structurally, oil leak is carefully considered in manufacturing, but the series is not made completely air-tight. Depending on your use or operating conditions, slight oil leak may be caused. If this has a problem with you, secure the sealability from the outside.

■このカタログ記載内容は2023年5月現在のものです。■本カタログに記載されている仕様・寸法等は改良のため、予告なく変更することがあります。■商品のカラーは印刷のため、実物と異なって見える場合があります。■本品の無償修理期間は、弊社が規定しております仕様条件内での使用を前提に、出荷後1年または実稼動2,500時間のどちらか早い到達時期といたします。■万一保証期間内において、明確に本品の品質起因による故障、不備が発生した場合、その対応を無償にて実施いたします。但し実機よりの脱着に関する工数、関連諸経費などは弊社負担外とさせていただきます。■お客様にて分解、改造等をなされた場合の無償修理対応は致しかねます。■弊社では海外におけるの保守およびサポートは行っていません。■不具合・修理のご依頼は、お買上げの販売店又は営業部までお問合せ下さい。

■The contents in the catalog is as of May, 2023. ■Specifications and dimensions are subject to change without notice. ■Product colors may look different from the catalog due to print. ■Q-Ten series ball reducers are warranted to be free from defects in material and workmanship for the shorter period of either 12 months after the date of the shipment or 2,500 hours of operation on condition that the Q-Ten ball reducers are installed properly and operated under conditions specified by Kamo Seiko. ■Defects in material and/or workmanship will result in replacement of defective unit by Kamo Seiko. The unit should be returned with freight prepaid to Kamo Seiko Corporation. ■Any cost in removing and/or installing the unit from/on the machine or facility should be owned by customer side. ■Kamo Seiko will not accept the free repair in case the unit is disassembled or modified. ■Kamo Seiko does not offer the services for maintenance and installation abroad. ■Please contact with Kamo Seiko or the local distributor for nonconformity or repair.

加茂精工株式会社

本社営業部
〒470-0424 愛知県豊田市御作町角割1166番地
TEL. 0565-76-0029(営)
URL www.kamo.co.jp

KAMO FA (韓国)
ソウル特別市衿川區加山洞550-1 A P T 形工場T. CASTLE1洞216号
TEL. 02-761-5621
URL www.kamofa.co.kr E-mail kamofa@kamofa.co.kr

加茂伝動科技(南京)有限公司(中国)
南京市秦淮区太平南路166号远洋国际中心北区3幢1单元901室 邮编:210001
TEL. 025-5223-0890
URL www.kamoasia.com E-mail ztc@kamoasia.com

KAMO SEIKO CORPORATION

HEAD OFFICE
1166 Kamewari, Mitsukuri-cho, Toyota-city, Aichi-prefecture 470-0424, JAPAN
Tel. +81-565-76-0029
URL www.kamo.co.jp

KOREA
KAMO FA 1Dong-216Ho IT Castle' Gasan-dong, Geumcheon-gu, Seoul, Rep of KOREA
Tel. +82-2-761-5621
URL www.kamofa.co.kr E-mail kamofa@kamofa.co.kr

CHINA
KAMO DT RM901, BLK3, North Ocean Int'l Center, 166 South Taiping Road, Nanjing, China ZIP:210001
Tel. +86-25-5223-0890
URL www.kamoasia.com E-mail ztc@kamoasia.com

kamo

Yes We can! Yes I can!