

# ボール減速機シリーズ

kamo

Nonbacklash Ball Reducer Series



KAMO SEIKO CORP.

# ボールは究極の動力伝達エレメント

A ball is an ultimate power transmission element.

世界中で広がりを見せている生産ライン高度化の波。これを根幹で支え、動力として広く利用されているのがモーターです。しかし、モーターは一人ではその能力をフルに発揮することはできません。「減速機」というパートナーを得て初めて力を出すことができるのです。加茂精工株式会社は「新規有用なるものを創造・提案する」という創業来の理念に基づき、この減速機の分野で初めて歯車を使わずに、スチールボールを用いて駆動する「ボール減速機」を1987年に開発、実用化し広くFA機器産業に貢献しています。この他にも、私たちならではの他に類のない製品群「TCGシリーズ」や「パールデックスシリーズ」「エアインデックスシリーズ」をラインアップしています。

The wave of advanced production lines are now spreading around the world. This is supported by a foundation, and the motor has been widely used as power. However, the motor alone can not demonstrate their full potential. "Gear" is the first time can get power out of partners. Kamo Seiko Co., Ltd. "to create something Naru proposed" New based on the principle that the traditional establishment, first in the field of gear without this gear, using a steel ball driven "gear ball" to developed in 1987, and widely commercialized equipment industries contributed to the FA. Besides this, other products not only of our unique "TCG Series" and "Parudekkusushirizu" "Index Series" Air on a line-up.

## ノンバックラッシュ

### Non-backlash

減速部に歯車ではなく多数のスチールボールを採用しています。予圧による常時転がり接触のため、バックラッシュは極小です。

Many steel balls are employed to reduction portion instead of toothed wheels. Rolling contact due to preset pressure enables users to minimize amount of backlash.

## 低騒音

### Low Level Noise

回転部はすべて転がり接触のためボール転走音のみです。ギヤのように歯打ち音は皆無です。静粛性が評価される医療機器等にも適しています。

There is only rolling ball noise due to the rolling contact of steel balls at all rotating members. There is no meshing or flexing gear noise at all. Therefore, The ball reducer is used for medical equipment, which requires quiet.

## コンパクト & シンプル

### Compact & Simple

減速機構部と、入・出力軸受部をハウジングに内蔵し、コンパクトな形にまとめ上げ、入出力同心型の減速機として、簡便な取付を実現しました。

By integrating a reducer mechanism and an input / output part into the housing the unit is assembled to be compact size, and the reducer with the concentricity of the input / output has materialized no dead space installation.

## メンテナンスフリー

### Maintenance-free

グリース封入でメンテナンスフリーです。オイル補給や交換が必要ありません。また、取付姿勢に制限が有りませんので設計の自由度もさらに広がります。

Filling grease makes it possible to be free of maintenance procedures. The ball type speed reducer does not restrict mounting posture, and insures extensive freedom of designs.

## 取付モータを選ばない

### Mounted to any motors

簡単なフランジを製作すれば、どんなモータにも対応できます。市販のステッピングモータをすぐに取付られる構造・寸法もご用意しております。

With simple flange arranged, it is possible to cope with any types of electric motors. We have instrument capable to instantly attach commercial stepping motor.

## 軽快高効率

### Nimble Action and High Efficiency

ボールネジ同様ボールの転がり接触なので、極めて軽快に作動します。ボール減速機はあらゆるモータの能力を最大限に活かします。

Like the case of ball type screw, rolling contact of balls enables users to extremely smooth actuation. Ball type speed reducer enables users to utilize any types of electric motors to the up-most capability.

# ボール減速機ラインアップ

BALL REDUCER PRODUCT LINEUP

Just-fit Ball Reducer

## 薄型ボール減速機 JFR series



減速比：10.5～40、モーター容量：200～1500  
Reduction ratio : 10.5-40, Motor capacity : 200-1500

P.8

出力軸に、専用の一体型クロスローラーベアリングを採用することにより、高い荷重に対応できます。また、オルダム機構を減らし、部品点数を削減。従来品より、30～50%の薄型を実現しています。

モーターアタッチメントを標準化にし、簡単にモーター取り付けができます。ボール減速機と同様に、ノンバックラッシの特徴は継承しています。

By employing dedicated, all-in-one cross roller bearings, the output shaft equipped can support higher loads. Also, the number of parts has been reduced by reducing the number of Oldham's joints, and the total thickness has been reduced by 30 - 50% compared with the conventional reducers.

The motor attachments, which have been standardized, can be attached easily to the motor. This series have taken over the non-backlash feature from our ball reducers of other series.

Strong Type Ball Reducer

## 強化型ボール減速機 SFP series



減速比：10～50、モーター容量：100～1500  
Reduction ratio : 10-50, Motor capacity : 100-1500

P.18

従来品（BR シリーズ）より、サイクロイド曲線を改良し、許容トルクを同じ型式と比べ 1.5 倍に向上させました。また、出力軸ベアリングを 3 点にし、ラジアル荷重も同型式より 2 倍に強化。

ボール減速機と同様に、ノンバックラッシ、高効率の特徴は継承しています。

The cycloid curve of the conventional reducers (BR series) has been improved. The allowable torque has been increased by 1.5 times compared with the same type reducers. The number of the output shaft bearings has been increased to 3 and the radial load has been doubled compared with the same type reducers.

This series have taken over the features of non-backlash and high efficiency from our ball reducers of other series.

Standard Type Ball Reducer

## ボール減速機 BR series



減速比：10～50、モーター容量：50～1500  
Reduction ratio : 10-50, Motor capacity : 50-1500

P.28

ボール減速機の基本形であり、スチールボールと出力軸、偏心軸にサイクロイド曲線を採用し、ノンバックラッシを実現しました。

また、複数歯が噛み合い、高効率です。歯打ち音も無く、転がり接触のため、低騒音です。

This series are basic ball reducers. By employing the cycloid curve for the steel balls, the output shaft and the eccentric shaft, non-backlash has been achieved.

By applying preload, multiple teeth can mesh with each other, realizing high efficiency. Thanks to rolling contact with no gear rattle, noise level is low.



# ボール減速機構&メカニズム

BALL SPEED REDUCTION MECHANISM

## サイクロイドボール減速（増速）機構の原理と特徴

Principle and characteristics of cycloid ball speed reduction (increase) mechanism

### 原理

PRINCIPLE

図1のように2枚の円板にボールを挟み、一方を固定、他方に偏心量 $e$ の公転を与えると、ボールは互いの円板上に直径 $e$ の円軌跡を描いて転がります。さらに、図2のように公転円板の1公転に対し、 $\theta$ 度の自転を与えながら公転を与えると、ボールの軌跡は固定円板に対し振幅 $e$ のエピ（外転）サイクロイド、公転円板に対して同振幅のハイポ（内転）サイクロイド曲線を描くこととなります（あるいはトロコイド曲線）。そこで発想を逆転すると図3のようになります。すなわち一方にエピサイクロイド曲線、他方にハイポサイクロイド曲線を中心軌跡としたボール溝を有する円板を、転動体であるボールを介して向かい合わせ、一方を固定、他方に公転を与えると、公転円板に2つの円板の波数の差に比例した自転が発生するわけです。そしてこの自転を、図1の円環溝を有する2つの整動板にて取り出すという機構であり、基本的には大小円の転がり運動から発生する自転公転運動と完全に等価となります。

かみ合いは図4に示すようにそれぞれの曲線間にいくつもの接点が生じ、そこにボールが位置するため、全ボールが溝によって必然的に位置拘束（かみ合い）され、かつ転がり接触により転動及びトルク伝達することになります。

### 減速比

REDUCTION RATIO

減速比とは、一方の波数 $N$ 、他方を $N-2$ としたとき、 $N$ 側に公転を与えたとき、 $i = 2/N$ となり、 $N-2$ 側に公転を与えたとき  $i = -2/(N-2)$  となります。つまり組み合わせの波数差は常に2であり、又、装着できるボール数は最大 $N-1$ となっています。



図1 Fig. 1



図2 Fig. 2

As shown in Fig. 1, when a ball is tucked between 2 discs while one disc being fixed and the other disc being revolved with an eccentric amount of  $e$ , the ball rolls over the disc insides with a circular locus of an  $e$  in diameter. Furthermore, as shown in Fig. 2, when the unfixed (revolving) disc is rotated at  $\theta^\circ$  per its revolution, the ball trace draws an epicycloid curve (outward rolling curve) of  $e$  in amplitude over the fixed disc inside and a hypocycloid curve (inward rolling curve) over the unfixed disc (revolving) inside (the latter is also called trochoid curve). Here, to think differently, as shown in Fig. 3, 2 discs having a ball groove as a centroid, respectively, where one disc having an epicycloid curve ball groove and the other disc having a hypocycloid curve ball groove, are positioned oppositely with a ball as a rolling element tucked between them. When one disc is fixed and the other disc is revolved, a rotation in proportion to the difference of the wavenumbers of the 2 discs generates on the revolving disc. And this rotation is mechanically taken out by using 2 motion-controlling plates, which is basically equivalent to the rotation and revolution motions generated by the rolling motions of 2 large and small circles.

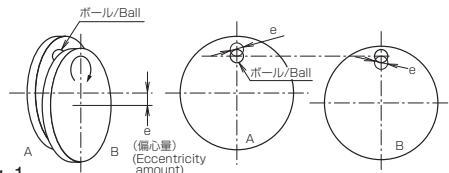
When it comes to mesh, as shown in Fig. 4, because multiple contact points are made between the respective curves and a ball is positioned in a contact point, all balls are constrained inevitably and positionally (i.e., meshed) and rolling motion and torque are transmitted by the rolling contact of the balls.

Assuming that the wavenumber of one disc is  $N$  and that of the other disc is  $N-2$ , when revolution is applied to the  $N$  side, the reduction ratio is  $i = 2/N$ , and when revolution is applied to the  $N-2$  side, the reduction ratio is  $i = -2/(N-2)$ . That is, the combinatorial wavenumber difference is always 2, and the maximum number of mountable balls is  $N-1$ .

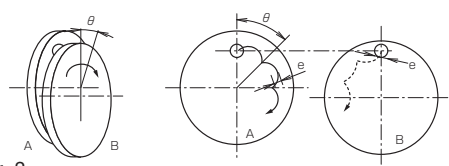

図3 Fig. 3



図4 Fig. 4

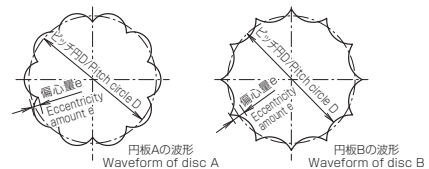

## ボール減速機メカニズム

### Mechanism of ball speed reducer

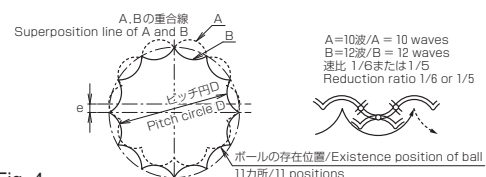
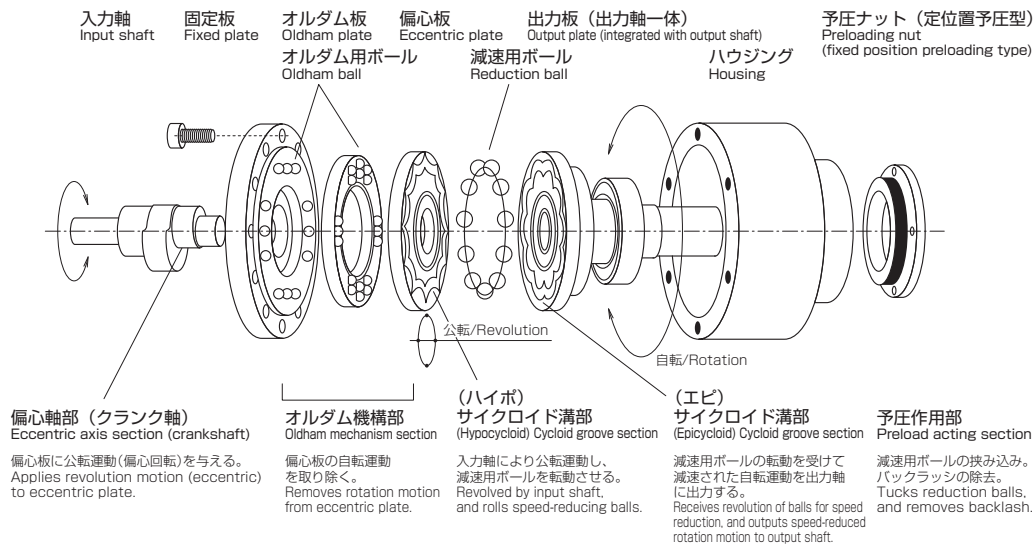

## ボール減速機メカニズム

### MECHANISM OF BALL SPEED REDUCER

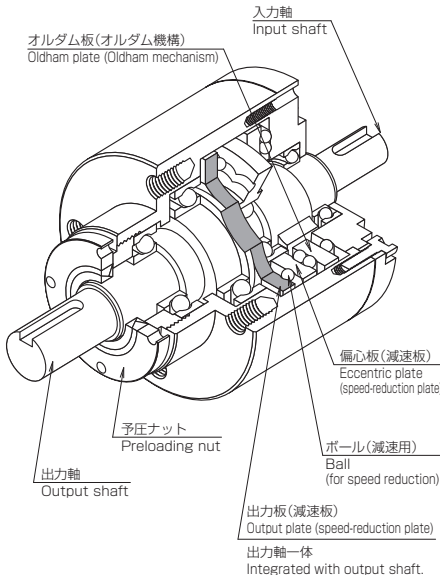

一般に歯車の噛み合っている歯は、1枚か2枚であり、例えば 100 枚の歯数を持つ歯車では、作用していない歯は 98～99 であり、いかにも無駄な構造になっています。そこで、残っている歯に多数の歯車を配すれば噛み合う歯数も増加し、動力伝達容量を大きく出来、装置も小型化できます。このような歯車として、遊星歯車、調和歯車、鼓形ウォームギヤなどがありますが、その噛み合いをさらに多くしたものがボール減速機です。

構造としては、内外歯車による差動歯車機構の一種に類しますが、歯車の歯部による動力伝達とは異なり、ボール（鋼球）の転動を介して動力を伝えるため、摩擦が少なく、ほとんどのボールが運動伝達に関与しているので、小型でも伝達容量が大きく、ノンバックラッシュを可能にしています。

In general, the number of teeth of a gear in mesh is only one or two. For example, when a gear has 100 teeth, the number of teeth not in mesh is 98 – 99. This structure is quite a wasteful. In view of this, if many gears are arranged to operate with the remaining teeth not in mesh of the gear, the number of teeth in mesh increases, the power transmission capacity increases, and the mechanism is downsized. Gears arranged like this include planetary gear, harmonic gear and drum-shaped worm gear. The ball reducer is one of such gear arrangements but with more number of teeth in mesh.

Structurally, the ball reducer is categorized as a type of the differential gear mechanisms using the differential motion of internal and external gears. However, unlike power transmission through gear teeth, power is transmitted through the rolling of balls (steel balls). Therefore, because almost all balls are involved in power transmission, the ball speed reducer is featured by low friction and large transmission capacity despite its small size, and non-backlash operation.



## ボール減速機の応用例

APPLICATION OF BALL REDUCER

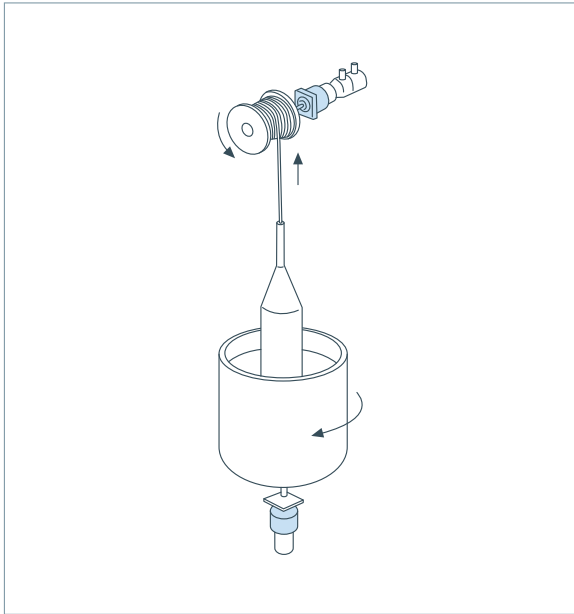

引き上げ装置の駆動  
Driving a pull-up unit

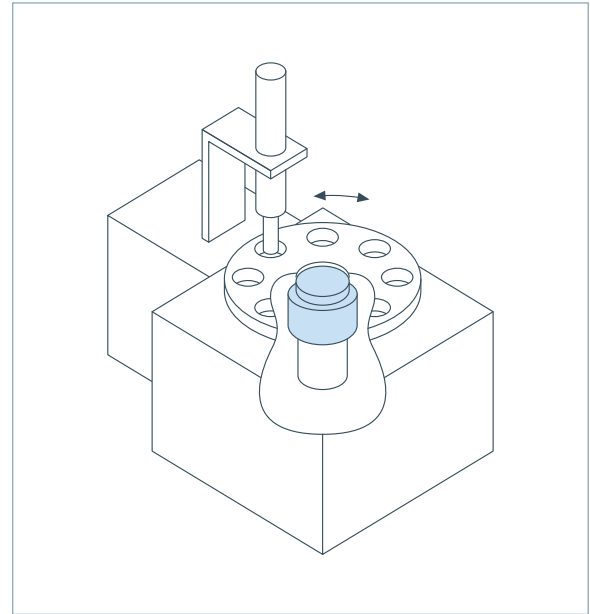

インデックステーブルの駆動  
Driving an index table

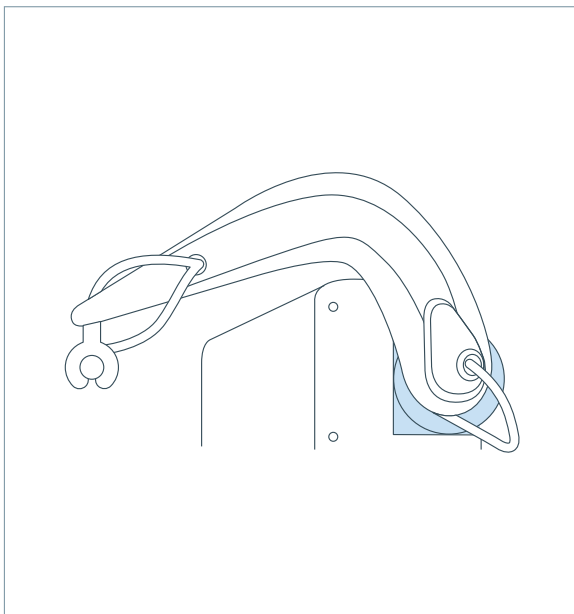

ロボットのアーム軸駆動  
Driving a robot arm shaft

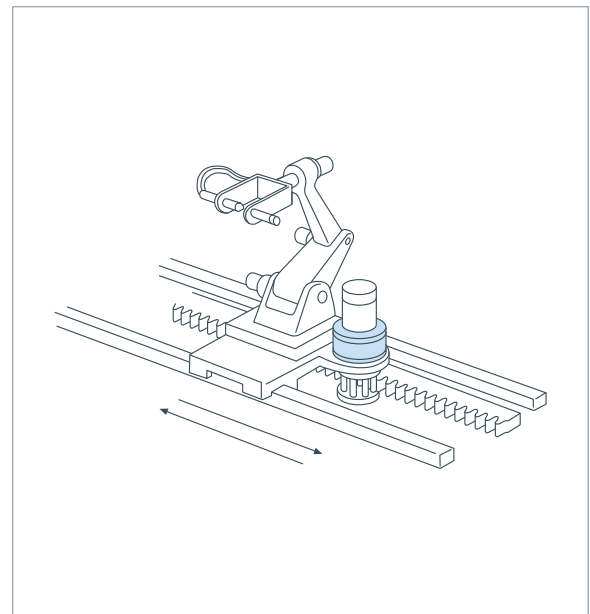

走行軸の駆動 (イラストは TCG との組合せ)  
Driving a traveling shaft (combined with the TCG in illustration)

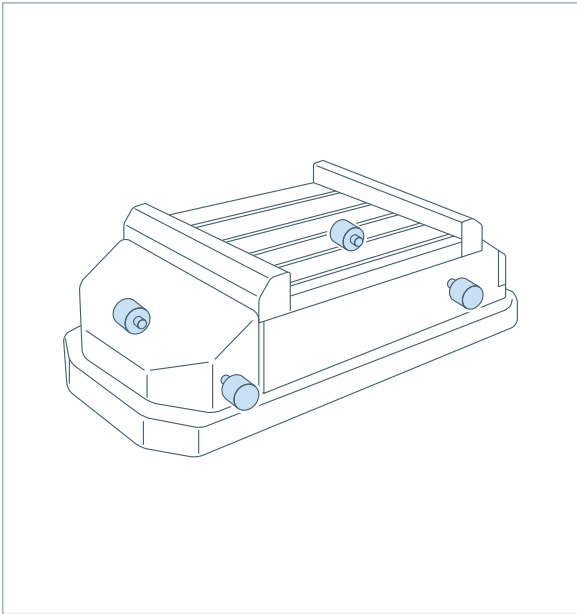

**AGV 車輪の駆動**  
Driving an AGV wheel

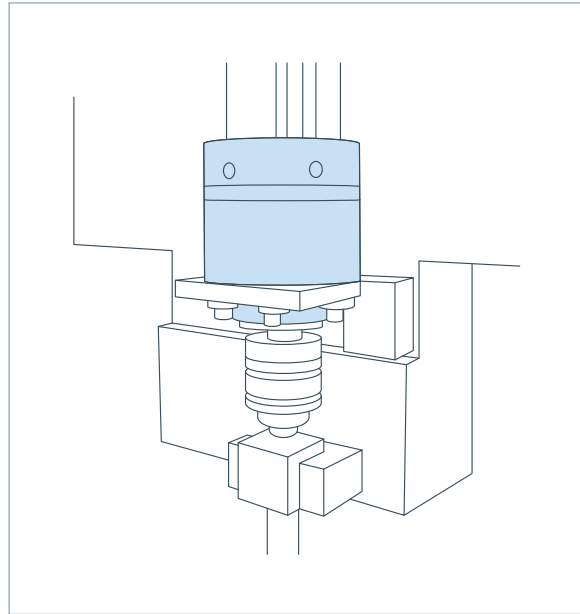

**ボールねじの駆動**  
Driving a ball screw

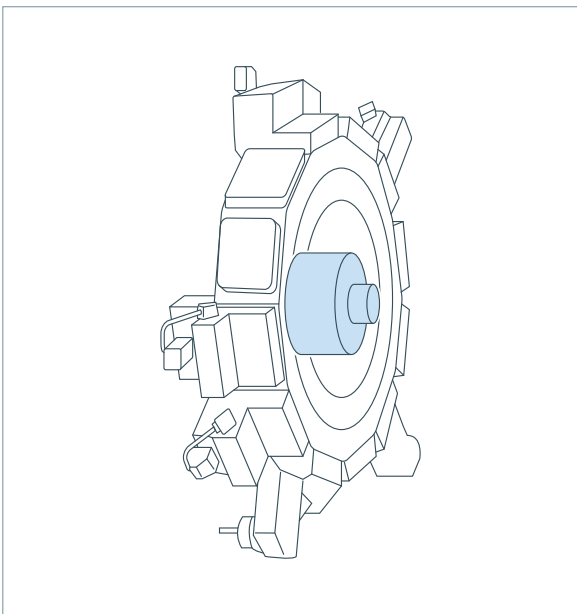

**工作機械の ATC 駆動**  
ATC drive unit for machine tools

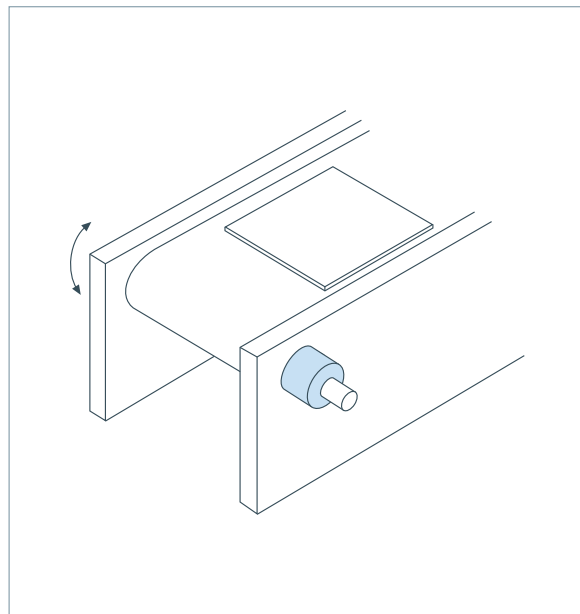

**ベルトコンベアーの駆動部**  
Driving a belt conveyor

# 薄型ボール減速機

JUST-FIT BALL REDUCER

# JFR Series

## 構造図 Structural Drawing

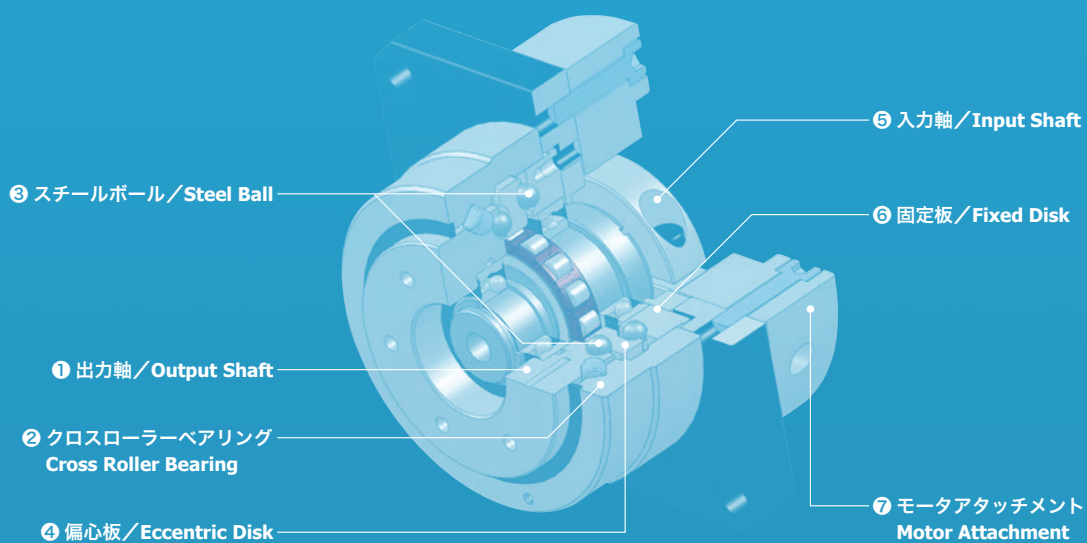



# JFR Series

## JFR仕様 JFR Specifications

型 式 Model		JFR60				JFR90					JFR120						
減速比 Reduction ratio		10.5	15	20	30	10.5	15	20	30	40	10.5	15	20	30	40		
回転方向(入力軸に対する出力軸の回転方向) Rotation direction (Rotation direction of output shaft correlated to input shaft)		逆方向 Reverse				逆方向 Reverse					逆方向 Reverse						
許容定格トルク Allowable rated torque	N · m	8.5	9.4	10.4	10.5	25.9	28.5	30.8	30.5	29	63.4	70	81.4	77.5	72.3		
加速時ピークトルク Acceleration peak torque	N · m	25.5	27.9	31.2	29.6	77.7	81	81.7	91.5	87	190.2	210	244.2	232.5	198.5		
瞬時最大トルク Max. instantaneous torque	N · m	50				180					450						
許容平均入力回転数 Allowable average number of input revolutions	rpm	3000				3000					3000						
最高入力回転数 Max input rpm	rpm	4500				4500					4500						
推奨モータ容量 Recommendable motor capacity	W	200				400					750						
入力軸換算慣性モーメント Inertia moment converted to input shaft	出力軸U型タイプ Output shaft U-shaped type	×10 <sup>-4</sup> kg · m <sup>2</sup>		0.152	0.153	0.154	0.155	0.655	0.659	0.667	0.672	0.677	2.66	2.66	2.69	2.71	2.74
	出力軸S型タイプ Output shaft S-shaped type			0.154	0.154	0.155	0.155	0.664	0.664	0.669	0.673	0.677	2.72	2.69	2.70	2.72	2.75
入力軸穴径 Input shaft hole diameter	mm	14				19					24						
		11				16					22						
		8				14					19						
						11					16						
						10					14						
				8													

連続回転にて使用される場合は弊社にご相談ください。 When you intend to use in continuous revolution, please consult us.

## 型式表示 Model Indication

### JFR型番 JFR model No.

JFR  A -  -  -

●出力軸オプション(S型のみ) : A…標準、B…キー溝付き、C…先端タップ、D…B+C  
Output shaft option (only for S type) : A…Standard, B…With keyway, C…Tip tap, D…B+C

●モータ情報 : P14~18までの「モータ・減速機対応表」の5桁の数字を入力して下さい。  
Motor information : Input the 5-digit number referring to the "Motor and Reduction Ratio Correspondence Table" on P. 14 - 18.

●減速比 : 10.5、15、20、30、40 (60型は除く)  
Reduction ratio : 10.5, 15, 20, 30, 40 (Excluding 60 type)

●入力軸形状 : C Input shaft shape : C

●出力軸形状 : U、S Output shaft shape : U, S

●枠番 : 60、90、120 Frame number : 60, 90, 120

外形寸法図 Outside Dimensional Drawing

JFR60

出力軸U型 Output shaft U type

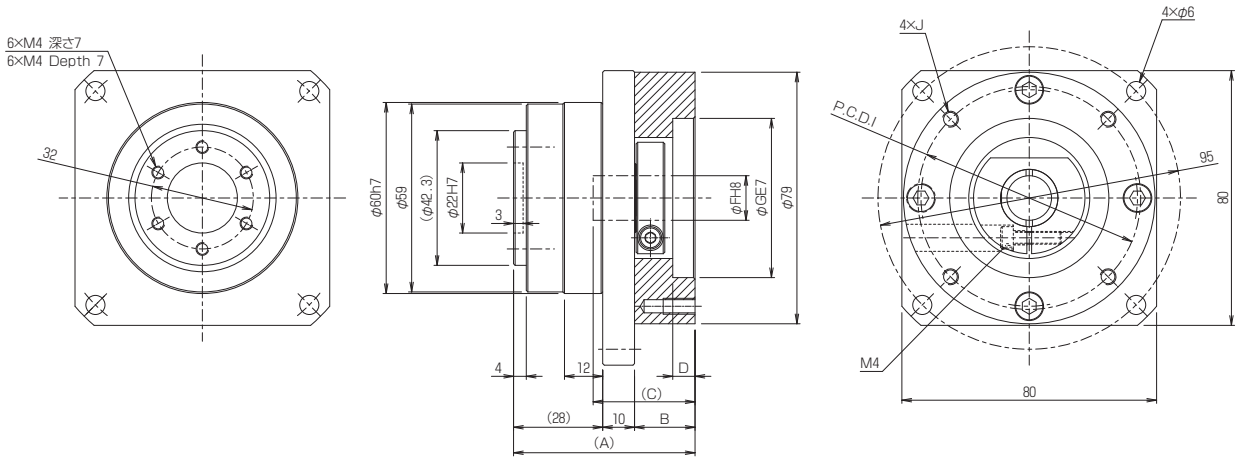

出力軸S型 Output shaft S type

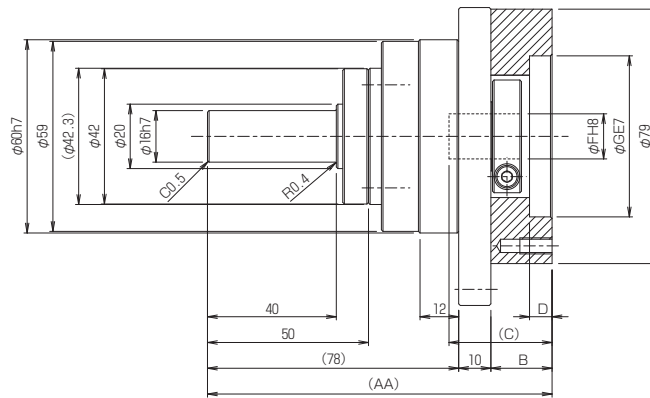

寸法表 Dimension Table

型式 Model	A	AA	B	C	D	$\phi F$	$\phi G$	I	J	質量 Mass weight kg
A01	55	105	17	27	5	8	30	$\phi 46$	M4 × 8	出力軸U型 Output shaft U type 0.9
B01	57	107	19	32	7	11	50	$\phi 70$		
B02						14			M5 × 10	出力軸S型 Output shaft S type 1.1

A : 出力軸U型全長 Overall length of output shaft U type  
 AA : 出力軸S型全長 Overall length of output shaft S type

JFR90

出力軸U型 Output shaft U type

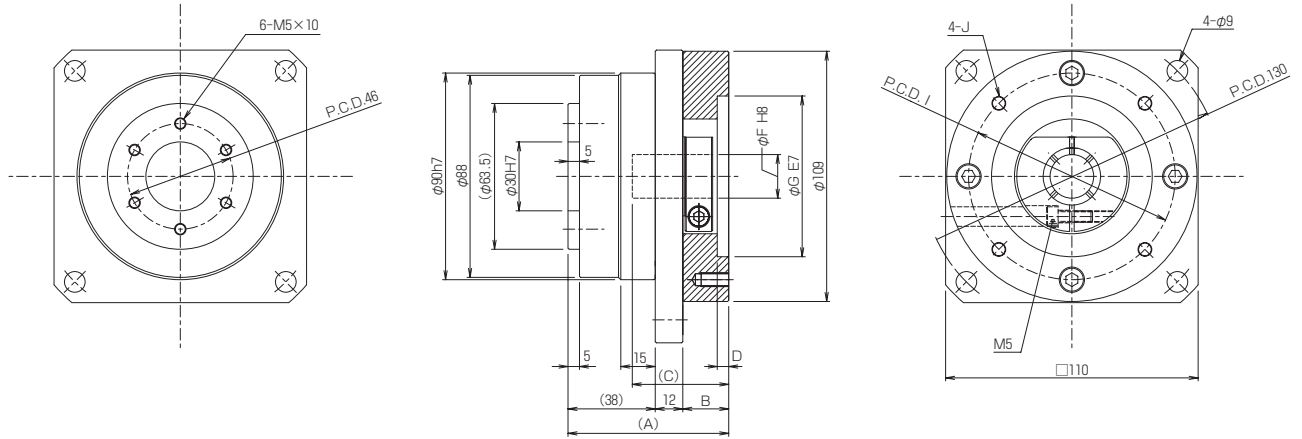

出力軸S型 Output shaft S type

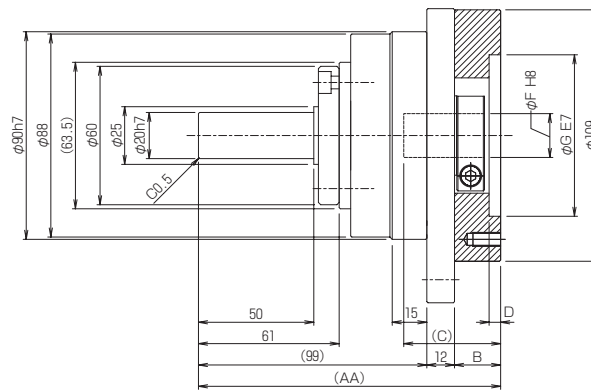

寸法表 Dimension Table

型式 Model	A	AA	B	C	D	φF	φG	I	J	質量 Mass weight kg
C01	70	131	20	26	5	8	36	□50	M4×8	出力軸U型 Output shaft U type 2.8 出力軸S型 Output shaft S type 3.2
C02				39		10				
C03				39		11・14				
C04				42		14	60	□70	M6×12	
C05				39		14	70	φ90	M5×10	
C06				42		16・19	70	φ90	M6×12	
D01	75	136	25	44	10	11・14	70	φ90	M5×10	出力軸U型 Output shaft U type 2.9 出力軸S型 Output shaft S type 3.3
D02						14			M6×12	

A : 出力軸U型全長 Overall length of output shaft U type  
AA : 出力軸S型全長 Overall length of output shaft S type

外形寸法図 Outside Dimensional Drawing

JFR120

出力軸U型 Output shaft U type

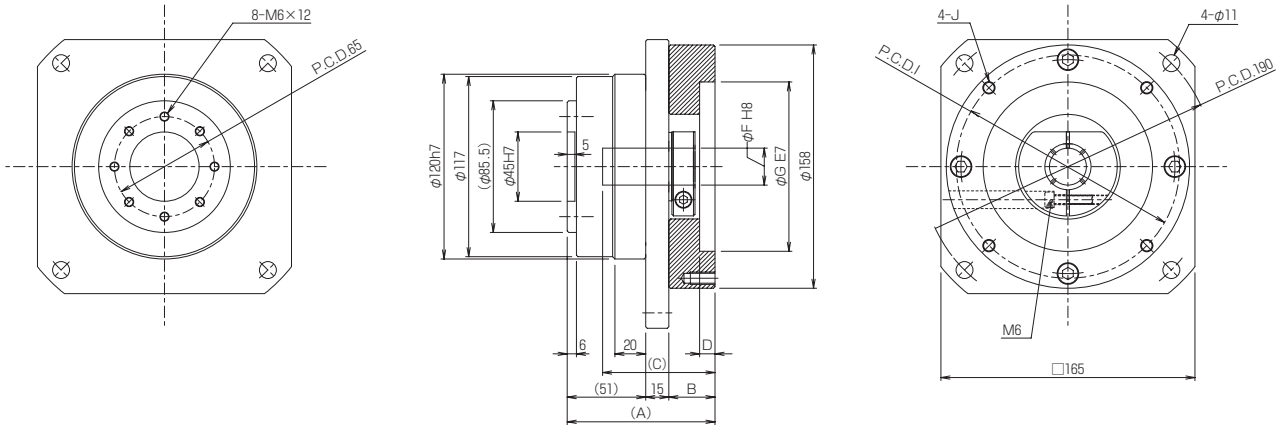

出力軸S型 Output shaft S type

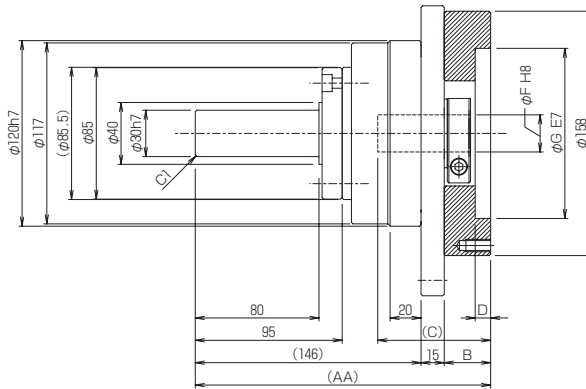

寸法表 Dimension Table

型式 Model	A	AA	B	C	D	φF	φG	I	J	質量 Mass weight kg
E01	96	191	30	44	10	14	50	φ70	M4×8	出力軸U型 Output shaft U type 7.4
E02				39					M5×10	
E03				55					M6×12	
E04	91	186	25	39	5	19	70	φ90	M5×10	出力軸S型 Output shaft S type 8.9
E05				55					M6×12	
F01				96					191	
F02	60	16・19	80		φ100	M6×12				
F03	68	24	95		φ115	M8×16				
F04	60	16・19								
F05	68	24	110		φ145					
F06	44	16・19								
G01	101	196	35	73	10	22	70	φ90	M6×12	出力軸U型 Output shaft U type 8.0 出力軸S型 Output shaft S type 9.5
H01	106	201	40	70	10	19	110	φ145	M8×16	出力軸U型 Output shaft U type 8.3 出力軸S型 Output shaft S type 9.8

A : 出力軸U型全長 Overall length of output shaft U type  
AA : 出力軸S型全長 Overall length of output shaft S type

## 出力軸オプション Output Shaft Option

オプションB(キー溝付)  
Option code B(Keyway)

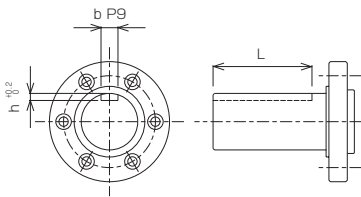

オプションC(先端タップ付)  
Option code C(Tip tap)

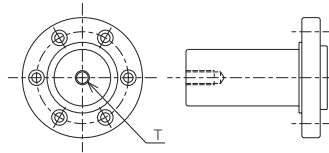

オプションD(キー溝・先端タップ付)  
Option code D(Keyway · tip tap)

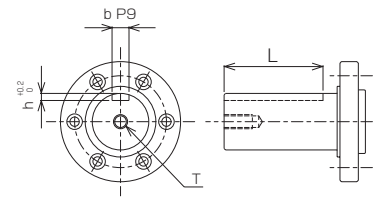

L・b・hはオプションB・Dのみ、TはオプションC・Dのみ

L & b & h is available in option code B & D only, T has option code C & D only.

型式 Model	L	b	h	T
<b>JFR60</b>	36	5	3	M5深サ10 M5 Depth 10
<b>JFR90</b>	45	6	3.5	M6深サ12 M6 Depth 12
<b>JFR120</b>	70	8	4	M8深サ16 M8 Depth 16



モータ・減速機対応表 Motor and Reduction Ratio Correspondence Table

モータ・減速機対応表は簡易表です。必ず型式選定計算を行ってください。グレー表示の型式は、減速機加速時ピークトルクを超えないようにご注意ください。掲載されていないモータ型式については弊社にお問い合わせください。

Since the Motor and Reduction Ratio Correspondence Table is a simplified presentation, be sure to make a model selecting calculation. Please use so that the peak torque during acceleration of the reducer is not exceeded about the motor mounting Number in gray colour. For any motor model not listed here, please consult us.

Panasonic

■の型式は減速機加速時ピークトルクを超えないようにご注意ください。  
Please be careful so that the peak torque during acceleration of the speed reducer is not exceeded about the motor mounting Number in gray colour.

モータ型式 Motor Model		JFR型式・減速比 JFR model · Reduction ratio														
		JFR60				JFR90					JFR120					
		10.5	15	20	30	10.5	15	20	30	40	10.5	15	20	30	40	
A6	MSMF	02	B0111	B0111	B0111	B0111	C0211	C0211	C0211	C0211	C0211					
		04					C0214	C0214	C0214	C0214	C0214	E0114	E0114	E0114	E0114	E0114
		08					C0519	C0519	C0519	C0519	C0519	E0419	E0419	E0419	E0419	E0419
		09					C0519	C0519	C0519	C0519	C0519	E0419	E0419	E0419	E0419	E0419
		10										F0419	F0419	F0419	F0419	F0419
		15										F0419	F0419	F0419	F0419	F0419
	MQMF	02					D0111	D0111	D0111	D0111	D0111					
		04					D0114	D0114	D0114	D0114	D0114	F0114	F0114	F0114	F0114	F0114
	MHMF	02	B0111	B0111	B0111	B0111	C0211	C0211	C0211	C0211	C0211					
		04					C0214	C0214	C0214	C0214	C0214	E0114	E0114	E0114	E0114	E0114
		08					C0519	C0519	C0519	C0519	C0519	E0419	E0419	E0419	E0419	E0419
		09					C0519	C0519	C0519	C0519	C0519	E0419	E0419	E0419	E0419	E0419
		10										G0122	G0122	G0122	G0122	G0122
		15										G0122	G0122	G0122	G0122	G0122
	MDMF	10										F0522	F0522	F0522	F0522	F0522
		15										F0522	F0522	F0522	F0522	F0522
	MGMF	09										F0522	F0522	F0522	F0522	F0522
		13										F0522	F0522	F0522	F0522	F0522
		18										F0522	F0522	F0522	F0522	F0522
	A5	MSME	02	B0111	B0111	B0111	B0111	C0211	C0211	C0211	C0211	C0211				
04							C0214	C0214	C0214	C0214	C0214	E0114	E0114	E0114	E0114	E0114
08							C0519	C0519	C0519	C0519	C0519	E0419	E0419	E0419	E0419	E0419
10												F0419	F0419	F0419	F0419	F0419
15												F0419	F0419	F0419	F0419	F0419
MSMD		02	B0111	B0111	B0111	B0111	C0211	C0211	C0211	C0211	C0211					
		04					C0214	C0214	C0214	C0214	C0214	E0114	E0114	E0114	E0114	E0114
		08					C0519	C0519	C0519	C0519	C0519	E0419	E0419	E0419	E0419	E0419
MDME		10										F0522	F0522	F0522	F0522	F0522
		15										F0522	F0522	F0522	F0522	F0522
MGME		09									G0122	G0122	G0122	G0122	G0122	
MHME		10										G0122	G0122	G0122	G0122	G0122
		15										G0122	G0122	G0122	G0122	G0122
MHMD		02	B0111	B0111	B0111	B0111	C0211	C0211	C0211	C0211	C0211					
		04					C0214	C0214	C0214	C0214	C0214	E0114	E0114	E0114	E0114	E0114
		08					C0519	C0519	C0519	C0519	C0519	E0419	E0419	E0419	E0419	E0419

※オイルシール付は除きます。 Excluding motor models which set the shaft part with the oil seal.

三菱電機 Mitsubishi Electric

の型式は減速機加速時ピークトルクを超えないようにご注意ください。  
 Please be careful so that the peak torque during acceleration of the speed reducer is not exceeded about the motor mounting Number in gray colour.

モータ型式 Motor Model		JFR型式・減速比 JFR model · Reduction ratio														
		JFR60				JFR90					JFR120					
		10.5	15	20	30	10.5	15	20	30	40	10.5	15	20	30	40	
J5	HK-KT	1M3W	A0108	A0108	A0108	A0108										
		23W	B0214	B0214	B0214	B0214	C0314	C0314	C0314	C0314	C0314	E0214	E0214	E0214	E0214	E0214
		43W	B0214	B0214	B0214	B0214	C0314	C0314	C0314	C0314	C0314	E0214	E0214	E0214	E0214	E0214
		63W	B0214	B0214	B0214	B0214	C0314	C0314	C0314	C0314	C0314	E0214	E0214	E0214	E0214	E0214
		23UW					C0614	C0614	C0614	C0614	C0614	E0514	E0514	E0514	E0514	E0514
		43UW					C0614	C0614	C0614	C0614	C0614	E0514	E0514	E0514	E0514	E0514
		7M3W					C0619	C0619	C0619	C0619	C0619	E0519	E0519	E0519	E0519	E0519
		103W					C0619	C0619	C0619	C0619	C0619	E0519	E0519	E0519	E0519	E0519
		7M3UW										F0219	F0219	F0219	F0219	F0219
		103UW										F0219	F0219	F0219	F0219	F0219
	153W										F0219	F0219	F0219	F0219	F0219	
	HK-ST	52W										F0524	F0524	F0524	F0524	F0524
		102W										F0524	F0524	F0524	F0524	F0524
		524W										F0524	F0524	F0524	F0524	F0524
		1024W										F0524	F0524	F0524	F0524	F0524
1724W											F0524	F0524	F0524	F0524	F0524	
2024AW											F0524	F0524	F0524	F0524	F0524	
J4	HG-KR	23	B0214	B0214	B0214	B0214	C0314	C0314	C0314	C0314	C0314	E0214	E0214	E0214	E0214	E0214
		43	B0214	B0214	B0214	B0214	C0314	C0314	C0314	C0314	C0314	E0214	E0214	E0214	E0214	E0214
		73					C0619	C0619	C0619	C0619	C0619	E0519	E0519	E0519	E0519	E0519
	HG-MR	23	B0214	B0214	B0214	B0214	C0314	C0314	C0314	C0314	C0314	E0214	E0214	E0214	E0214	E0214
		43	B0214	B0214	B0214	B0214	C0314	C0314	C0314	C0314	C0314	E0214	E0214	E0214	E0214	E0214
		73					C0619	C0619	C0619	C0619	C0619	E0519	E0519	E0519	E0519	E0519
	HG-SR	51										F0524	F0524	F0524	F0524	F0524
		81										F0524	F0524	F0524	F0524	F0524
		52										F0524	F0524	F0524	F0524	F0524
		102										F0524	F0524	F0524	F0524	F0524
		152										F0524	F0524	F0524	F0524	F0524
	HG-RR	103										F0424	F0424	F0424	F0424	F0424
153											F0424	F0424	F0424	F0424	F0424	

モータ・減速機対応表 Motor and Reduction Ratio Correspondence Table

安川電機 Yaskawa Electric

■の型式は減速機加速時ピークトルクを超えないようご注意ください。  
 Please be careful so that the peak torque during acceleration of the speed reducer is not exceeded about the motor mounting Number in gray colour.

モータ型式 Motor Model		JFR型式・減速比 JFR model · Reduction ratio														
		JFR60				JFR90					JFR120					
		10.5	15	20	30	10.5	15	20	30	40	10.5	15	20	30	40	
Σ-X	SGMXJ	C2A	A0108	A0108	A0108	A0108										
		02A	B0214	B0214	B0214	B0214	C0314	C0314	C0314	C0314	C0314	E0214	E0214	E0214	E0214	
		04A	B0214	B0214	B0214	B0214	C0314	C0314	C0314	C0314	C0314	E0214	E0214	E0214	E0214	
		06A	B0214	B0214	B0214	B0214	C0314	C0314	C0314	C0314	C0314	E0214	E0214	E0214	E0214	
		08A					C0619	C0619	C0619	C0619	C0619	E0519	E0519	E0519	E0519	
	SGMXA	C2A	A0108	A0108	A0108	A0108										
		02A	B0214	B0214	B0214	B0214	C0314	C0314	C0314	C0314	C0314	E0214	E0214	E0214	E0214	
		04A	B0214	B0214	B0214	B0214	C0314	C0314	C0314	C0314	C0314	E0214	E0214	E0214	E0214	
		06A	B0214	B0214	B0214	B0214	C0314	C0314	C0314	C0314	C0314	E0214	E0214	E0214	E0214	
		08A					C0619	C0619	C0619	C0619	C0619	E0519	E0519	E0519	E0519	
		10A					C0619	C0619	C0619	C0619	C0619	E0519	E0519	E0519	E0519	
	SGMXG	09A										F0524	F0524	F0524	F0524	
		13A										F0524	F0524	F0524	F0524	
		20A										F0524	F0524	F0524	F0524	
	Σ-7	SGM7J	C2A	A0108	A0108	A0108	A0108									
02A			B0214	B0214	B0214	B0214	C0314	C0314	C0314	C0314	C0314	E0214	E0214	E0214	E0214	
04A			B0214	B0214	B0214	B0214	C0314	C0314	C0314	C0314	C0314	E0214	E0214	E0214	E0214	
06A			B0214	B0214	B0214	B0214	C0314	C0314	C0314	C0314	C0314	E0214	E0214	E0214	E0214	
08A							C0619	C0619	C0619	C0619	C0619	E0519	E0519	E0519	E0519	
SGM7A		C2A	A0108	A0108	A0108	A0108										
		02A	B0214	B0214	B0214	B0214	C0314	C0314	C0314	C0314	C0314	E0214	E0214	E0214	E0214	
		04A	B0214	B0214	B0214	B0214	C0314	C0314	C0314	C0314	C0314	E0214	E0214	E0214	E0214	
		06A	B0214	B0214	B0214	B0214	C0314	C0314	C0314	C0314	C0314	E0214	E0214	E0214	E0214	
		08A					C0619	C0619	C0619	C0619	C0619	E0519	E0519	E0519	E0519	
		10A					C0619	C0619	C0619	C0619	C0619	E0519	E0519	E0519	E0519	
		15A										F0324	F0324	F0324	F0324	
SGM7P		02A					C0614	C0614	C0614	C0614	C0614	E0514	E0514	E0514	E0514	
		04A					C0614	C0614	C0614	C0614	C0614	E0514	E0514	E0514	E0514	
SGM7G		03A										F0216	F0216	F0216	F0216	
		05A										F0216	F0216	F0216	F0216	
		09A										F0524	F0524	F0524	F0524	
		13A										F0524	F0524	F0524	F0524	
		20A										F0524	F0524	F0524	F0524	

※オイルシール付は除きます。 Excluding motor models which set the shaft part with the oil seal.

**富士電機 Fuji Electric**

の型式は減速機加速時ピークトルクを超えないようにご注意ください。  
 Please be careful so that the peak torque during acceleration of the speed reducer is not exceeded about the motor mounting Number in gray colour.

モータ型式 Motor Model		JFR型式・減速比 JFR model · Reduction ratio														
		JFR60				JFR90					JFR120					
		10.5	15	20	30	10.5	15	20	30	40	10.5	15	20	30	40	
GYS	201	B0214	B0214	B0214	B0214	C0314	C0314	C0314	C0314	C0314	E0214	E0214	E0214	E0214	E0214	
	401	B0214	B0214	B0214	B0214	C0314	C0314	C0314	C0314	C0314	E0214	E0214	E0214	E0214	E0214	
	751					C0616	C0616	C0616	C0616	C0616	E0516	E0516	E0516	E0516	E0516	
	102										F0424	F0424	F0424	F0424	F0424	
	152										F0424	F0424	F0424	F0424	F0424	
GYC	201					C0614	C0614	C0614	C0614	C0614	E0514	E0514	E0514	E0514	E0514	
	401					C0614	C0614	C0614	C0614	C0614	E0514	E0514	E0514	E0514	E0514	
	751										F0416	F0416	F0416	F0416	F0416	
	102										F0524	F0524	F0524	F0524	F0524	
	152										F0524	F0524	F0524	F0524	F0524	
GYG	501C										F0519	F0519	F0519	F0519	F0519	
	751C										F0519	F0519	F0519	F0519	F0519	
	102C										F0522	F0522	F0522	F0522	F0522	
	152C										F0522	F0522	F0522	F0522	F0522	
GYB	201	B0214	B0214	B0214	B0214	C0314	C0314	C0314	C0314	C0314	E0214	E0214	E0214	E0214	E0214	
	401	B0214	B0214	B0214	B0214	C0314	C0314	C0314	C0314	C0314	E0214	E0214	E0214	E0214	E0214	
	751					C0619	C0619	C0619	C0619	C0619	E0519	E0519	E0519	E0519	E0519	

**キーエンス KEYENCE**

の型式は減速機加速時ピークトルクを超えないようにご注意ください。  
 Please be careful so that the peak torque during acceleration of the speed reducer is not exceeded about the motor mounting Number in gray colour.

モータ型式 Motor Model		JFR型式・減速比 JFR model · Reduction ratio														
		JFR60				JFR90					JFR120					
		10.5	15	20	30	10.5	15	20	30	40	10.5	15	20	30	40	
SV2	020	B0214	B0214	B0214	B0214	C0314	C0314	C0314	C0314	C0314	E0214	E0214	E0214	E0214	E0214	
	040	B0214	B0214	B0214	B0214	C0314	C0314	C0314	C0314	C0314	E0214	E0214	E0214	E0214	E0214	
	075					C0619	C0619	C0619	C0619	C0619	E0519	E0519	E0519	E0519	E0519	
	100										F0524	F0524	F0524	F0524	F0524	
	150										F0524	F0524	F0524	F0524	F0524	
	200										F0524	F0524	F0524	F0524	F0524	

**オムロン OMRON**

の型式は減速機加速時ピークトルクを超えないようにご注意ください。  
 Please be careful so that the peak torque during acceleration of the speed reducer is not exceeded about the motor mounting Number in gray colour.

モータ型式 Motor Model		JFR型式・減速比 JFR model · Reduction ratio														
		JFR60				JFR90					JFR120					
		10.5	15	20	30	10.5	15	20	30	40	10.5	15	20	30	40	
1S	R88M-	1M20030	B0111	B0111	B0111	B0111	C0211	C0211	C0211	C0211	C0211					
		1M40030					C0214	C0214	C0214	C0214	C0214	E0114	E0114	E0114	E0114	E0114
		1M75030					C0519	C0519	C0519	C0519	C0519	E0419	E0419	E0419	E0419	E0419
		1M1K020										F0522	F0522	F0522	F0522	F0522
		1M1K520										F0522	F0522	F0522	F0522	F0522
		1L1K030										F0419	F0419	F0419	F0419	F0419
		1L1K530										F0419	F0419	F0419	F0419	F0419
		1AM20030	B0111	B0111	B0111	B0111	C0211	C0211	C0211	C0211	C0211					
		1AM40030					C0214	C0214	C0214	C0214	C0214	E0114	E0114	E0114	E0114	E0114
		1AM75030					C0519	C0519	C0519	C0519	C0519	E0419	E0419	E0419	E0419	E0419
		1AL1K030										F0419	F0419	F0419	F0419	F0419
1AL1K530										F0419	F0419	F0419	F0419	F0419		
G5	R88M-	K20030	B0111	B0111	B0111	B0111	C0211	C0211	C0211	C0211	C0211					
		K40030					C0214	C0214	C0214	C0214	C0214	E0114	E0114	E0114	E0114	E0114
		K75030					C0519	C0519	C0519	C0519	C0519	E0419	E0419	E0419	E0419	E0419
		K1K030										F0419	F0419	F0419	F0419	F0419
		K1K530										F0419	F0419	F0419	F0419	F0419
		K1K020										F0522	F0522	F0522	F0522	F0522
		K1K520										F0522	F0522	F0522	F0522	F0522

# 強化型ボール減速機

STRONG TYPE BALL REDUCER

# SFP Series

## 構造図 Structural Drawing

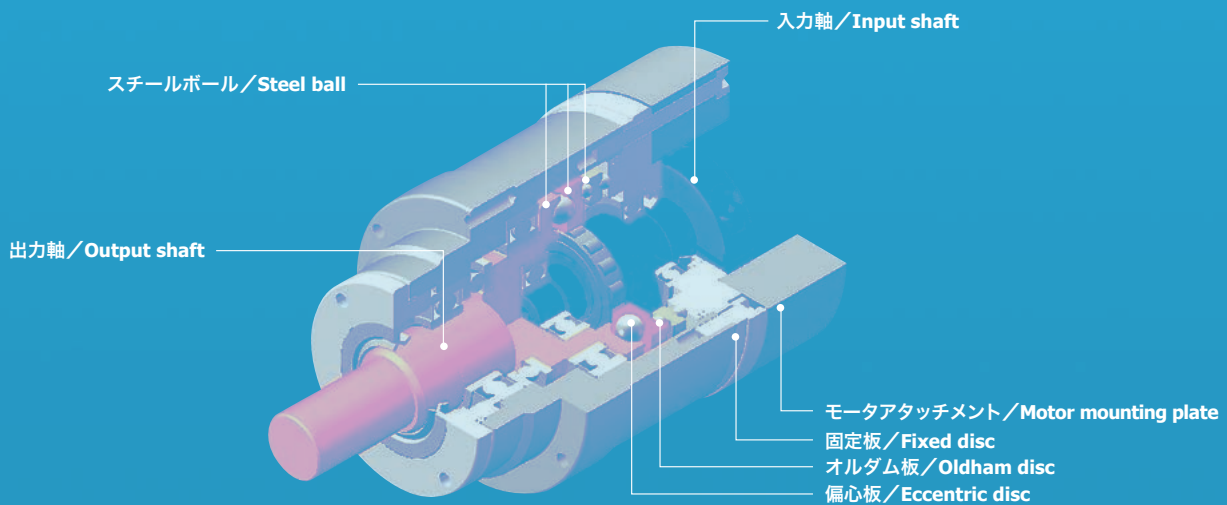



# SFP Series

## SFP-S型仕様 SFP-S Specifications

型 式 Model	SFP70SCA				SFP85SCA				SFP100SCA				SFP125SCA						
	減速比 Reduction ratio	8	10	20	30	10	20	30	40	10	20	30	40	10	20	30	40	50	
回転方向 (入力軸に対する出力軸の回転方向) Rotation direction (Rotation direction of output shaft correlated to input shaft)	逆方向 Reverse		同方向 Forward		逆方向 Reverse	同方向 Forward			逆方向 Reverse	同方向 Forward			逆方向 Reverse	同方向 Forward					
許容定格トルク Allowable rated torque	N · m		10	11	12	12.8	25.5	28.4	26.2	26	48.8	56	56	56	90	96.5	96.5	98.8	99.2
加速時ピークトルク Max. instantaneous torque	N · m		20	21.2	22	22.6	42	48.3	44.6	44.2	78	89.4	95.2	95.2	155	168.9	168.9	172.9	173.6
瞬時最大トルク Max. instantaneous torque	N · m		40		70	85		130	160		240	270							
出力軸許容ラジアル荷重 <sup>※1</sup> Allowable radial load at output shaft	N		500		1000		1500		2000										
出力軸許容スラスト荷重 <sup>※1</sup> Allowable thrust load at output shaft	N		200		400		600		1000										
許容平均入力回転数 Allowable average number of input revolutions	rpm		3000		3000		2000		2000										
最高入力回転数 Max input rpm	rpm		4500		4500		4000		4000										
入力軸換算慣性モーメント Inertia moment converted to input shaft	$\times 10^{-4} \text{kg} \cdot \text{m}^2$		0.149	0.149	0.159	0.161	0.484	0.431	0.414	0.406	1.58	1.43	1.38	1.36	3.45	2.98	2.86	2.81	2.78
推奨モータ容量 Recommendable motor capacity	W		200	200	100	100	400	200	200	100	750	400	400	200	1500	750	750	400	400
入力軸穴径 Input shaft hole diameter	mm		14		14		19		24										
			11		11		16		22										
			8		8		14		19										
							11		16										
									14										

※1 許容ラジアル荷重は軸方向の負荷位置が各軸の先端の場合となります。  
This allowable radial load value is realized when the load positioned in the axial direction is the figure at top of shaft.

## 型式表示 Model Indication

### SFP型式(S型) Model SFP (Type S)

SFP    S C A -   -     -   00

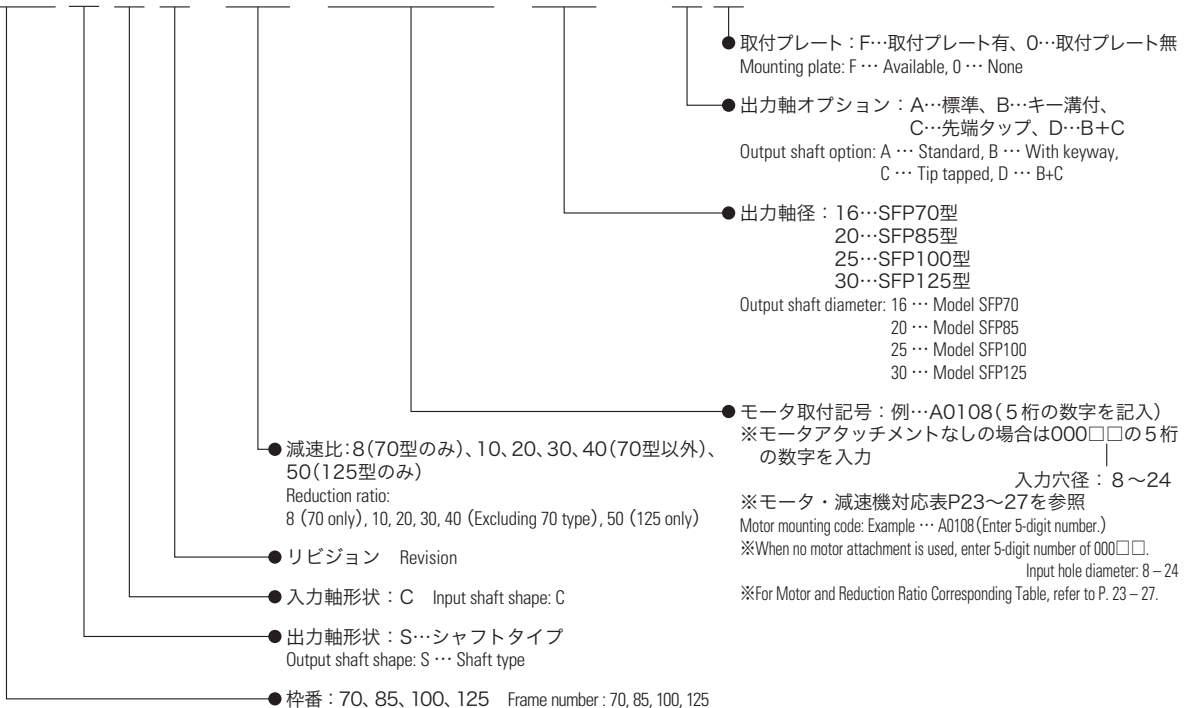

外形寸法図 Outside Dimensional Drawing

SFP70

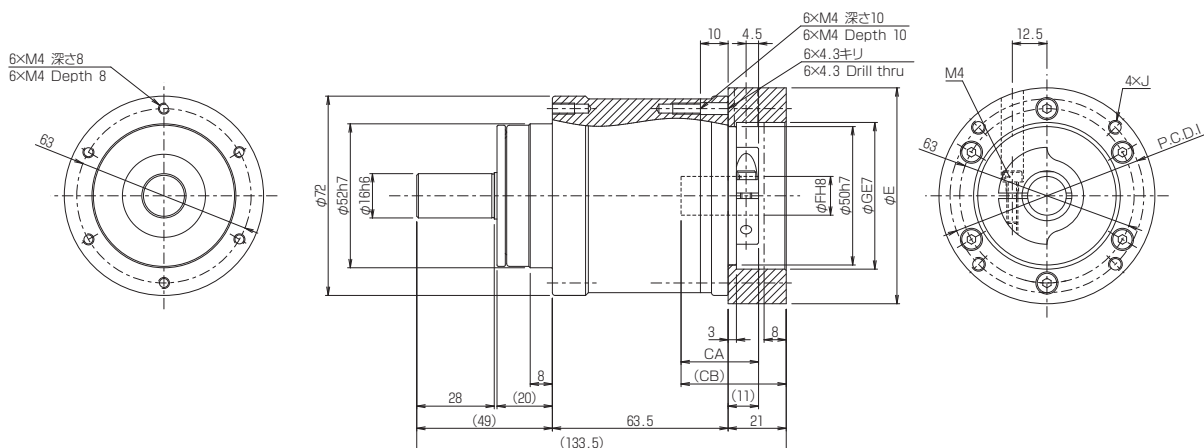

寸法表 Dimension Table

型式 Model	CA	CB	E	F	G	I	J	質量 Mass weight kg
A01	23	33	72	8	30	22	M3×6	1.4
A02						45		
A03						46		
B01	28	38	78	8	50	70	M4×8	
				11				
B02	23	33	78	8	50	70	M5×10	
	28	38		14				

※モータアタッチメントがない場合の質量は、1.3kg Mass with no motor attachment: 1.3kg

SFP85

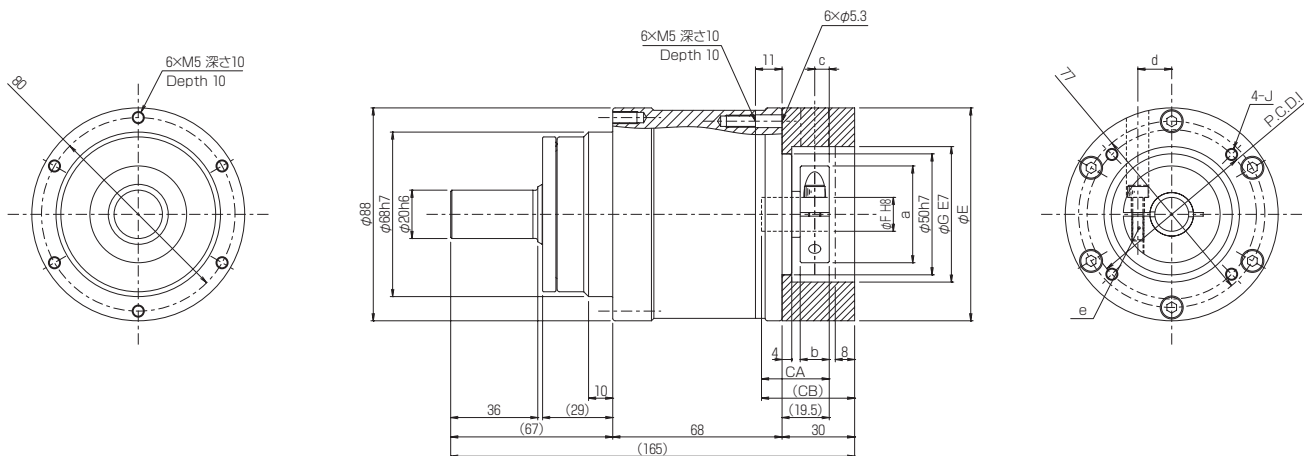

寸法表 Dimension Table

型式 Model	CA	CB	E	F	G	I	J	a	b	c	d	e	質量 Mass weight kg
C01	23	33.5	88	8	30	45	M3×6	30	10	5	10	M4	3.6
C02						46							
C03						40							
C04	28	38.5	98	11・14	50	70	M4×8	30	10	5	10	M5	
				8									
D01	28	38.5	98	14	70	90	M5×10	30	10	5	10	M4	
D02				11・14									
D02	28	38.5	98	14	70	90	M6×12	40	12	6	14	M5	
D02				14									

※モータアタッチメントがない場合の質量は、3.2kg Mass with no motor attachment: 3.2kg

SFP100

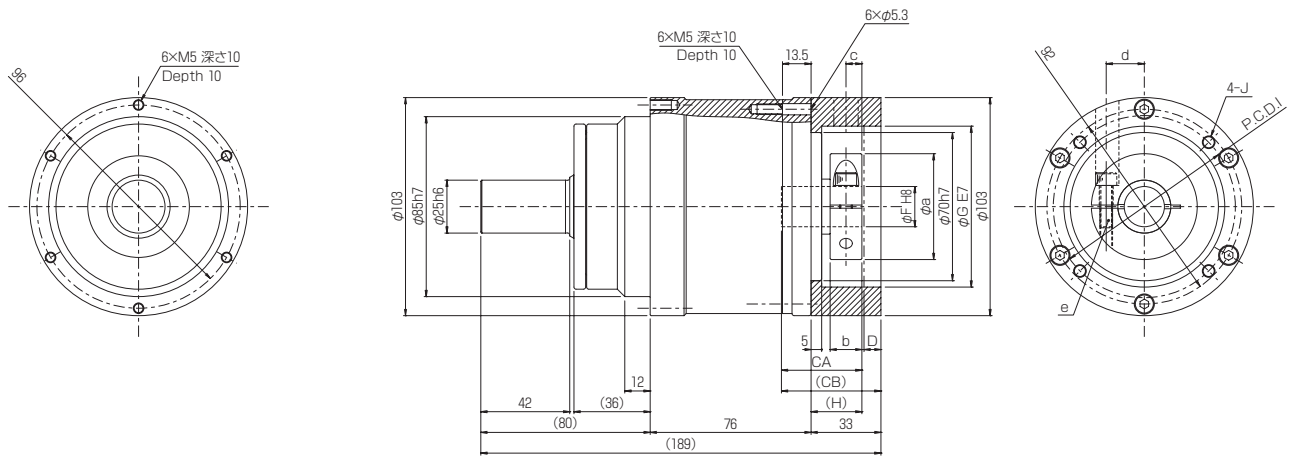

寸法表 Dimension Table

型式 Model	CA	CB	D	F	G	H	I	J	a	b	c	d	e	質量 Mass weight kg
E01	28	40	5	11・14	50	21	70	M4 x8	40	12	6	14	M5	5.8
E02				14										
E03				11・14										
E04	38	47	8	19	70	24	90	M5x10	50	15	7.5	18	M6	5.7
E05				14										
E06				16・19										

※モータアタッチメントがない場合の質量は、5.3kg Mass with no motor attachment: 5.3kg

SFP125

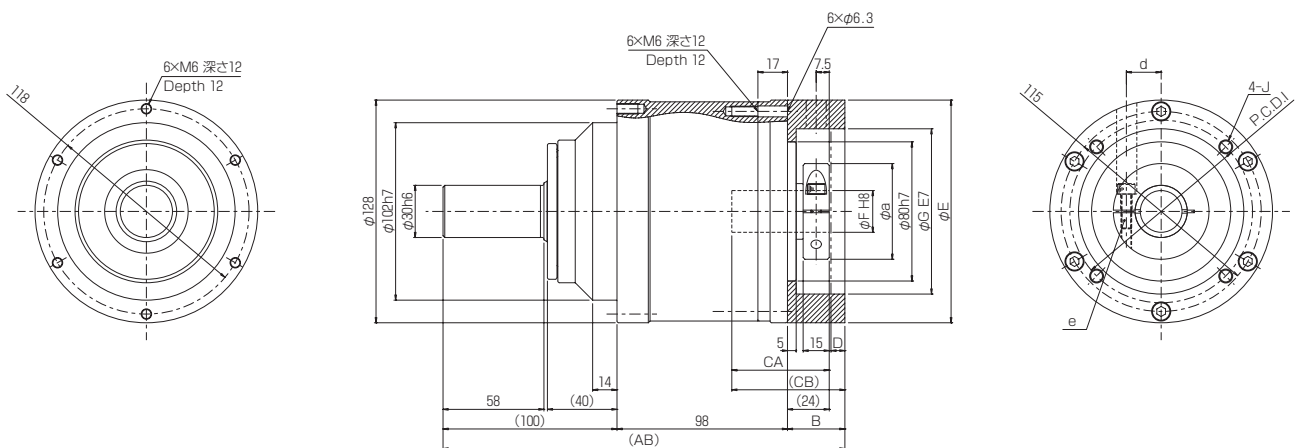

寸法表 Dimension Table

型式 Model	AB	B	CA	CB	D	E	F	G	I	J	a	b	c	d	e	質量 Mass weight kg
F01	231	33	38	47	5	128	14	50	70	M4x10	40	12	6	14	M5	10.9
F02							14									
F03							19									
F04	231	33	38	47	8	128	16・19	70	90	M5x10	50	15	7.5	18	M6	10.8
F05							14									
F06							16・19									
F07	231	33	56	65	8	128	24	80	100	M6x12	40	12	6	14	M5	10.7
F08							24									
G01							24									
G02	242	44	38	58	10	158	16・19	110	145	M8x16	50	15	7.5	18	M6	11.7
G02							22・24									

※モータアタッチメントがない場合の質量は、10.1kg Mass with no motor attachment: 10.1kg

## オプション Option

## SFP出力軸オプション SFP Output Shaft Option

型式 Model	b <sub>1</sub> P9	t <sub>1</sub>	l <sub>1</sub>	NT
SFP70	5	3 $\begin{smallmatrix} +0.1 \\ 0 \end{smallmatrix}$	20	M5×10
SFP85	6	3.5 $\begin{smallmatrix} +0.1 \\ 0 \end{smallmatrix}$	25	M6×12
SFP100	6	3.5 $\begin{smallmatrix} +0.1 \\ 0 \end{smallmatrix}$	32	M6×12
SFP125	8	4 $\begin{smallmatrix} +0.2 \\ 0 \end{smallmatrix}$	50	M8×16

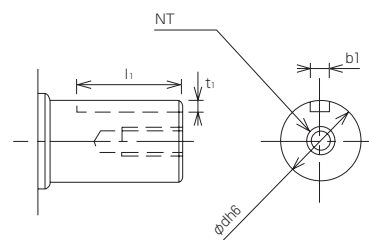

## SFP取付プレート SFP Mounting Plate

型式 Model	A	B	C	D	E	F	G	H	I	J
SFP70	100	68	8	50	34	7	86	10.5	45	6.5
SFP85	125	88	10	62.5	44	8.5	108	13	60	9
SFP100	145	103	12	72.5	51.5	10	125	13	75	11
SFP125	170	128	14	85	64	10	150	18	90	11

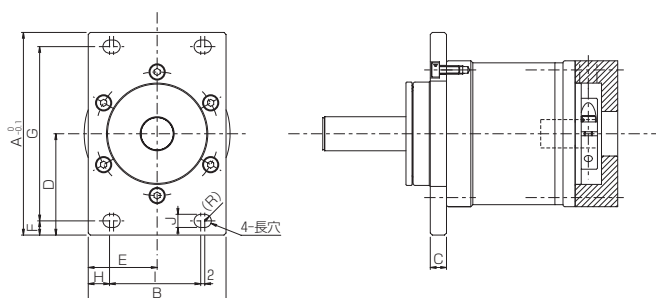

モータ・減速機対応表 Motor and Reduction Ratio Correspondence Table

モータ・減速機対応表は簡易表です。必ず型式選定計算を行ってください。グレー表示の型式は、減速機加速時ピークトルクを超えないようにご使用ください。掲載されていないモータ型式については弊社にお問い合わせください。

Since the Motor and Reduction Ratio Correspondence Table is a simplified presentation, be sure to make a model selecting calculation. Please use so that the peak torque during acceleration of the reducer is not exceeded about the motor mounting Number in gray colour. For any motor model not listed here, please consult us.

三菱電機 Mitsubishi Electric

の型式は減速機加速時ピークトルクを超えないようにご注意ください。  
Please be careful so that the peak torque during acceleration of the speed reducer is not exceeded about the motor mounting Number in gray colour.

モータ型式 Motor Model		SFP形式・減速比 SFP model・Reduction ratio																	
		SFP70				SFP85				SFP100				SFP125					
		8	10	20	30	10	20	30	40	10	20	30	40	10	20	30	40	50	
J5	HK-KT	13W	A0308	A0308	A0308	A0308	C0208	C0208	C0208	C0208									
		1M3W	A0308	A0308	A0308	A0308	C0208	C0208	C0208	C0208									
		13UW	B0208	B0208	B0208	B0208	C0408	C0408	C0408	C0408									
		23W	B0214	B0214	B0214	B0214	C0414	C0414	C0414	C0414	E0214	E0214	E0214	E0214	F0214	F0214	F0214	F0214	F0214
		43W	B0214	B0214	B0214	B0214	C0414	C0414	C0414	C0414	E0214	E0214	E0214	E0214	F0214	F0214	F0214	F0214	F0214
		63W	B0214	B0214	B0214	B0214	C0414	C0414	C0414	C0414	E0214	E0214	E0214	E0214	F0214	F0214	F0214	F0214	F0214
		23UW					D0214	D0214	D0214	D0214	E0514	E0514	E0514	E0514	F0414	F0414	F0414	F0414	F0414
		43UW					D0214	D0214	D0214	D0214	E0514	E0514	E0514	E0514	F0414	F0414	F0414	F0414	F0414
		7M3W									E0619	E0619	E0619	E0619	F0419	F0419	F0419	F0419	F0419
		103W									E0619	E0619	E0619	E0619	F0419	F0419	F0419	F0419	F0419
	7M3UW													F0519	F0519	F0519	F0519	F0519	
	103UW													F0519	F0519	F0519	F0519	F0519	
	153W													F0519	F0519	F0519	F0519	F0519	
	HK-ST	52W													G0224	G0224	G0224	G0224	G0224
		102W													G0224	G0224	G0224	G0224	G0224
524W														G0224	G0224	G0224	G0224	G0224	
1024W														G0224	G0224	G0224	G0224	G0224	
1724W														G0224	G0224	G0224	G0224	G0224	
2024AW													G0224	G0224	G0224	G0224	G0224		
J4	HG-KR	13	A0308	A0308	A0308	A0308	C0208	C0208	C0208	C0208									
		23	B0214	B0214	B0214	B0214	C0414	C0414	C0414	C0414	E0214	E0214	E0214	E0214	F0214	F0214	F0214	F0214	F0214
		43	B0214	B0214	B0214	B0214	C0414	C0414	C0414	C0414	E0214	E0214	E0214	E0214	F0214	F0214	F0214	F0214	F0214
		73									E0619	E0619	E0619	E0619	F0419	F0419	F0419	F0419	F0419
	HG-MR	13	A0308	A0308	A0308	A0308	C0208	C0208	C0208	C0208									
		23	B0214	B0214	B0214	B0214	C0414	C0414	C0414	C0414	E0214	E0214	E0214	E0214	F0214	F0214	F0214	F0214	F0214
		43	B0214	B0214	B0214	B0214	C0414	C0414	C0414	C0414	E0214	E0214	E0214	E0214	F0214	F0214	F0214	F0214	F0214
		73									E0619	E0619	E0619	E0619	F0419	F0419	F0419	F0419	F0419
	HG-SR	51													G0224	G0224	G0224	G0224	G0224
		81													G0224	G0224	G0224	G0224	G0224
		52													G0224	G0224	G0224	G0224	G0224
		102													G0224	G0224	G0224	G0224	G0224
		152													G0224	G0224	G0224	G0224	G0224
	HG-RR	103													F0724	F0724	F0724	F0724	F0724
		153													F0724	F0724	F0724	F0724	F0724



モータ・減速機対応表 Motor and Reduction Ratio Correspondence Table

安川電機 Yaskawa Electric

■の型式は減速機加速時ピークトルクを超えないようご注意ください。  
Please be careful so that the peak torque during acceleration of the speed reducer is not exceeded about the motor mounting Number in gray colour.

モータ型式 Motor Model		SFP型式・減速比 SFP model · Reduction ratio																	
		SFP70				SFP85				SFP100				SFP125					
		8	10	20	30	10	20	30	40	10	20	30	40	10	20	30	40	50	
Σ-X	SGMXJ	01A	A0308	A0308	A0308	A0308	C0208	C0208	C0208	C0208									
		C2A	A0308	A0308	A0308	A0308	C0208	C0208	C0208	C0208									
		02A	B0214	B0214	B0214	B0214	C0414	C0414	C0414	C0414	E0214	E0214	E0214	E0214	F0214	F0214	F0214	F0214	F0214
		04A	B0214	B0214	B0214	B0214	C0414	C0414	C0414	C0414	E0214	E0214	E0214	E0214	F0214	F0214	F0214	F0214	F0214
		06A	B0214	B0214	B0214	B0214	C0414	C0414	C0414	C0414	E0214	E0214	E0214	E0214	F0214	F0214	F0214	F0214	F0214
		08A									E0619	E0619	E0619	E0619	F0419	F0419	F0419	F0419	F0419
	SGMXA	01A	A0308	A0308	A0308	A0308	C0208	C0208	C0208	C0208									
		C2A	A0308	A0308	A0308	A0308	C0208	C0208	C0208	C0208									
		02A	B0214	B0214	B0214	B0214	C0414	C0414	C0414	C0414	E0214	E0214	E0214	E0214	F0214	F0214	F0214	F0214	F0214
		04A	B0214	B0214	B0214	B0214	C0414	C0414	C0414	C0414	E0214	E0214	E0214	E0214	F0214	F0214	F0214	F0214	F0214
		06A	B0214	B0214	B0214	B0214	C0414	C0414	C0414	C0414	E0214	E0214	E0214	E0214	F0214	F0214	F0214	F0214	F0214
		08A									E0619	E0619	E0619	E0619	F0419	F0419	F0419	F0419	F0419
		10A									E0619	E0619	E0619	E0619	F0419	F0419	F0419	F0419	F0419
	SGMXG	09A													G0224	G0224	G0224	G0224	G0224
		13A													G0224	G0224	G0224	G0224	G0224
		20A													G0224	G0224	G0224	G0224	G0224
	Σ-7	SGM7J	01A	A0308	A0308	A0308	A0308	C0208	C0208	C0208	C0208								
			C2A	A0308	A0308	A0308	A0308	C0208	C0208	C0208	C0208								
02A			B0214	B0214	B0214	B0214	C0414	C0414	C0414	C0414	E0214	E0214	E0214	E0214	F0214	F0214	F0214	F0214	F0214
04A			B0214	B0214	B0214	B0214	C0414	C0414	C0414	C0414	E0214	E0214	E0214	E0214	F0214	F0214	F0214	F0214	F0214
06A			B0214	B0214	B0214	B0214	C0414	C0414	C0414	C0414	E0214	E0214	E0214	E0214	F0214	F0214	F0214	F0214	F0214
08A											E0619	E0619	E0619	E0619	F0419	F0419	F0419	F0419	F0419
SGM7A		01A	A0308	A0308	A0308	A0308	C0208	C0208	C0208	C0208									
		C2A	A0308	A0308	A0308	A0308	C0208	C0208	C0208	C0208									
		02A	B0214	B0214	B0214	B0214	C0414	C0414	C0414	C0414	E0214	E0214	E0214	E0214	F0214	F0214	F0214	F0214	F0214
		04A	B0214	B0214	B0214	B0214	C0414	C0414	C0414	C0414	E0214	E0214	E0214	E0214	F0214	F0214	F0214	F0214	F0214
		06A	B0214	B0214	B0214	B0214	C0414	C0414	C0414	C0414	E0214	E0214	E0214	E0214	F0214	F0214	F0214	F0214	F0214
		08A									E0619	E0619	E0619	E0619	F0419	F0419	F0419	F0419	F0419
		10A									E0619	E0619	E0619	E0619	F0419	F0419	F0419	F0419	F0419
		15A													F0624	F0624	F0624	F0624	F0624
SGM7P		01A	B0208	B0208	B0208	B0208	C0408	C0408	C0408	C0408									
		02A					D0214	D0214	D0214	D0214	E0514	E0514	E0514	E0514	F0414	F0414	F0414	F0414	F0414
		04A					D0214	D0214	D0214	D0214	E0514	E0514	E0514	E0514	F0414	F0414	F0414	F0414	F0414
SGM7G		03A													F0516	F0516	F0516	F0516	F0516
		05A													F0516	F0516	F0516	F0516	F0516
		09A													G0224	G0224	G0224	G0224	G0224
		13A													G0224	G0224	G0224	G0224	G0224
		20A													G0224	G0224	G0224	G0224	G0224

※オイルシール付は除きます。 Excluding motor models which set the shaft part with the oil seal.

**Panasonic**

■の型号は減速機加速時ピークトルクを超えないようにご注意ください。  
 Please be careful so that the peak torque during acceleration of the speed reducer is not exceeded about the motor mounting Number in gray colour.

モータ型式 Motor Model		SFP型式・減速比 SFP model · Reduction ratio																	
		SFP70				SFP85				SFP100				SFP125					
		8	10	20	30	10	20	30	40	10	20	30	40	10	20	30	40	50	
A6	MSMF	01	A0208	A0208	A0208	A0208	C0108	C0108	C0108	C0108									
		02	B0111	B0111	B0111	B0111	C0311	C0311	C0311	C0311	E0111	E0111	E0111	E0111					
		04					C0314	C0314	C0314	C0314	E0114	E0114	E0114	E0114	F0114	F0114	F0114	F0114	F0114
		08									E0419	E0419	E0419	E0419	F0319	F0319	F0319	F0319	F0319
		09									E0419	E0419	E0419	E0419	F0319	F0319	F0319	F0319	F0319
	MQMF	01	B0108	B0108	B0108	B0108	C0308	C0308	C0308	C0308									
		02					D0111	D0111	D0111	D0111	E0311	E0311	E0311	E0311					
		04					D0114	D0114	D0114	D0114	E0314	E0314	E0314	E0314	F0314	F0314	F0314	F0314	F0314
	MHMF	01	A0308	A0308	A0308	A0308	C0208	C0208	C0208	C0208									
		02	B0111	B0111	B0111	B0111	C0311	C0311	C0311	C0311	E0111	E0111	E0111	E0111					
		04					C0314	C0314	C0314	C0314	E0114	E0114	E0114	E0114	F0114	F0114	F0114	F0114	F0114
		08									E0419	E0419	E0419	E0419	F0319	F0319	F0319	F0319	F0319
		09									E0419	E0419	E0419	E0419	F0319	F0319	F0319	F0319	F0319
		10													G0222	G0222	G0222	G0222	G0222
		15													G0222	G0222	G0222	G0222	G0222
	MDMF	10													G0222	G0222	G0222	G0222	G0222
		15													G0222	G0222	G0222	G0222	G0222
	MGMF	09													G0222	G0222	G0222	G0222	G0222
		13													G0222	G0222	G0222	G0222	G0222
		18													G0222	G0222	G0222	G0222	G0222
A5	MSME	01	A0208	A0208	A0208	A0208	C0108	C0108	C0108	C0108									
		02	B0111	B0111	B0111	B0111	C0311	C0311	C0311	C0311	E0111	E0111	E0111	E0111					
		04					C0314	C0314	C0314	C0314	E0114	E0114	E0114	E0114	F0114	F0114	F0114	F0114	F0114
		08									E0419	E0419	E0419	E0419	F0319	F0319	F0319	F0319	F0319
	MSMD	01	A0208	A0208	A0208	A0208	C0108	C0108	C0108	C0108									
		02	B0111	B0111	B0111	B0111	C0311	C0311	C0311	C0311	E0111	E0111	E0111	E0111					
		04					C0314	C0314	C0314	C0314	E0114	E0114	E0114	E0114	F0114	F0114	F0114	F0114	F0114
		08									E0419	E0419	E0419	E0419	F0319	F0319	F0319	F0319	F0319
	MDME	10													G0222	G0222	G0222	G0222	G0222
		15													G0222	G0222	G0222	G0222	G0222
	MGME	09													G0222	G0222	G0222	G0222	G0222
	MHME	10													G0222	G0222	G0222	G0222	G0222
		15													G0222	G0222	G0222	G0222	G0222
	MHMD	02	B0111	B0111	B0111	B0111	C0311	C0311	C0311	C0311	E0111	E0111	E0111	E0111					
		04					C0314	C0314	C0314	C0314	E0114	E0114	E0114	E0114	F0114	F0114	F0114	F0114	F0114
08										E0419	E0419	E0419	E0419	F0319	F0319	F0319	F0319	F0319	

※オイルシール付は除きます。 Excluding motor models which set the shaft part with the oil seal.

モータ・減速機対応表 Motor and Reduction Ratio Correspondence Table

富士電機 Fuji Electric

■の型式は減速機加速時ピークトルクを超えないようにご注意ください。  
Please be careful so that the peak torque during acceleration of the speed reducer is not exceeded about the motor mounting Number in gray colour.

モータ型式 Moter Model		SFP型式・減速比 SFP model · Reduction ratio																
		SFP70				SFP85				SFP100				SFP125				
		8	10	20	30	10	20	30	40	10	20	30	40	10	20	30	40	50
GYS	101	A0308	A0308	A0308	A0308	C0208	C0208	C0208	C0208									
	201	B0214	B0214	B0214	B0214	C0414	C0414	C0414	C0414	E0214	E0214	E0214	E0214	F0214	F0214	F0214	F0214	F0214
	401	B0214	B0214	B0214	B0214	C0414	C0414	C0414	C0414	E0214	E0214	E0214	E0214	F0214	F0214	F0214	F0214	F0214
	751									E0616	E0616	E0616	E0616	F0416	F0416	F0416	F0416	F0416
	102													F0724	F0724	F0724	F0724	F0724
	152													F0724	F0724	F0724	F0724	F0724
GYC	101	B0208	B0208	B0208	B0208	C0408	C0408	C0408	C0408									
	201					D0214	D0214	D0214	D0214	E0514	E0514	E0514	E0514	F0414	F0414	F0414	F0414	F0414
	401					D0214	D0214	D0214	D0214	E0514	E0514	E0514	E0514	F0414	F0414	F0414	F0414	F0414
	751													F0816	F0816	F0816	F0816	F0816
	102													G0224	G0224	G0224	G0224	G0224
	152													G0224	G0224	G0224	G0224	G0224
GYG	501C													G0119	G0119	G0119	G0119	G0119
	751C													G0119	G0119	G0119	G0119	G0119
	102C													G0222	G0222	G0222	G0222	G0222
	152C													G0222	G0222	G0222	G0222	G0222
GYB	201	B0214	B0214	B0214	B0214	C0414	C0414	C0414	C0414	E0214	E0214	E0214	E0214	F0214	F0214	F0214	F0214	F0214
	401	B0214	B0214	B0214	B0214	C0414	C0414	C0414	C0414	E0214	E0214	E0214	E0214	F0214	F0214	F0214	F0214	F0214
	751									E0619	E0619	E0619	E0619	F0419	F0419	F0419	F0419	F0419

キーエンス KEYENCE

■の型式は減速機加速時ピークトルクを超えないようにご注意ください。  
Please be careful so that the peak torque during acceleration of the speed reducer is not exceeded about the motor mounting Number in gray colour.

モータ型式 Moter Model		SFP型式・減速比 SFP model · Reduction ratio																
		SFP70				SFP85				SFP100				SFP125				
		8	10	20	30	10	20	30	40	10	20	30	40	10	20	30	40	50
SV2	010	A0308	A0308	A0308	A0308	C0208	C0208	C0208	C0208									
	020	B0214	B0214	B0214	B0214	C0414	C0414	C0414	C0414	E0214	E0214	E0214	E0214	F0214	F0214	F0214	F0214	F0214
	040	B0214	B0214	B0214	B0214	C0414	C0414	C0414	C0414	E0214	E0214	E0214	E0214	F0214	F0214	F0214	F0214	F0214
	075									E0619	E0619	E0619	E0619	F0419	F0419	F0419	F0419	F0419
	100													G0224	G0224	G0224	G0224	G0224
	150													G0224	G0224	G0224	G0224	G0224
	200													G0224	G0224	G0224	G0224	G0224

## オムロン OMRON

■の型式は減速機加速時ピークトルクを超えないようにご注意ください。

Please be careful so that the peak torque during acceleration of the speed reducer is not exceeded about the motor mounting Number in gray colour.

モータ型式 Motor Model		SFP型式・減速比 SFP model · Reduction ratio																	
		SFP70				SFP85				SFP100				SFP125					
		8	10	20	30	10	20	30	40	10	20	30	40	10	20	30	40	50	
1S	R88M-	1M10030	A0308	A0308	A0308	A0308	C0208	C0208	C0208	C0208									
		1M20030	B0111	B0111	B0111	B0111	C0311	C0311	C0311	C0311	E0111	E0111	E0111	E0111					
		1M40030					C0314	C0314	C0314	C0314	E0114	E0114	E0114	E0114	F0114	F0114	F0114	F0114	F0114
		1M75030									E0419	E0419	E0419	E0419	F0319	F0319	F0319	F0319	F0319
		1M1K020													G0222	G0222	G0222	G0222	G0222
		1M1K520													G0222	G0222	G0222	G0222	G0222
		1AM20030	B0111	B0111	B0111	B0111	C0311	C0311	C0311	C0311	E0111	E0111	E0111	E0111					
		1AM40030					C0314	C0314	C0314	C0314	E0114	E0114	E0114	E0114	F0114	F0114	F0114	F0114	F0114
		1AM75030									E0419	E0419	E0419	E0419	F0319	F0319	F0319	F0319	F0319
G5	R88M-	K10030	A0308	A0308	A0308	A0308	C0208	C0208	C0208	C0208									
		K20030	B0111	B0111	B0111	B0111	C0311	C0311	C0311	C0311	E0111	E0111	E0111	E0111					
		K40030					C0314	C0314	C0314	C0314	E0114	E0114	E0114	E0114	F0114	F0114	F0114	F0114	F0114
		K75030									E0419	E0419	E0419	E0419	F0319	F0319	F0319	F0319	F0319
		K1K020													G0222	G0222	G0222	G0222	G0222
		K1K520													G0222	G0222	G0222	G0222	G0222

# ボール減速機

STANDARD TYPE BALL REDUCER

# BR Series

## 構造図 Structural Drawing

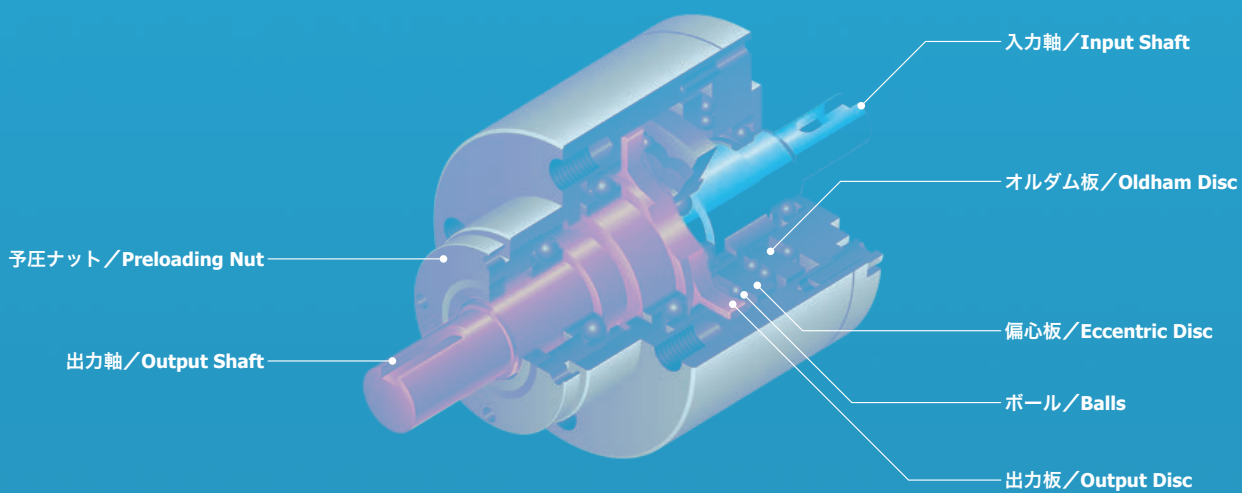

# BR Series

## BR仕様 BR Specifications

型式 Model	減速比 Reduction ratio	回転方向 (入力軸に対する 出力軸の回転方向) Rotational Direction (Rotation direction of output shaft compared to input shaft)	許容定格 トルク Allowable rated torque N・m	加速時 ピーク トルク Acceleration peak torque N・m	瞬時最大 トルク Max. Instantaneous torque N・m	許容平均入力 回転数 Allowable average number of input revolutions rpm	最高入力 回転数 Max.Input rpm	入力軸換算 慣性 モーメント Moment of inertia at Input shaft $\times 10^{-4} \text{kg} \cdot \text{m}^2$	出力軸端 At end of output shaft		入力軸端 At end of input shaft		質量 Mass Weight kg	
									許容ラジアル 荷重 Allowable radial load N	許容スラスト 荷重 Allowable thrust load N	許容ラジアル 荷重 Allowable radial load N	許容スラスト 荷重 Allowable thrust load N		
BR50	10	逆方向 Rev.	3.9	9.8	19.6	2400	3000	0.021	29	79	49	29	0.4 (SS・SH型) (SS・SH Model) 0.36 (US・UH型) (US・UH Model)	
	15	同方向 Fwd.	3.9	9.8	19.6									0.018
	18		3.9	9.8	19.6									
BR65	10	逆方向 Rev.	7.8	14.7	29.4	2400	3000	0.053	98	294	49	49	0.9 (SS・SH型) (SS・SH Model) 0.7 (US・UH型) (US・UH Model)	
	15		7.8	14.7	29.4									0.048
	20		6.9	12.7	25.5									
BR85	10	逆方向 Rev.	19.6	37.3	73.5	2400	3000	0.190	294	588	108	74	1.8 (SS・SH型) (SS・SH Model) 1.45 (US・UH型) (US・UH Model)	
	15		17.7	33.3	65.7									0.160
	20		15.7	29.4	58.8									
	30	同方向 Fwd.	14.7	27.5	54.9									0.140
BR100	10	逆方向 Rev.	34.3	58.8	117.7	2300	3000	0.650	490	981	147	98	3.6 (SS・SH型) (SS・SH Model) 3.0 (US・UH型) (US・UH Model)	
	20		31.4	53.0	105.9									0.520
	30		24.5	42.2	82.4									
	40		24.5	41.2	83.4									0.440
BR125	10	逆方向 Rev.	68.6	117.7	235.4	2200	3000	1.810	785	1471	186	147	6.4 (SS・SH型) (SS・SH Model) 4.9 (US・UH型) (US・UH Model)	
	20		68.6	117.7	235.4									1.400
	30		51.0	86.3	172.6									
	50		44.1	74.5	150.0									1.170
BR160	10	逆方向 Rev.	98.1	176.5	353.0	2000	2500	5.200	981	1961	441	294	14.2 (SS・SH型) (SS・SH Model) 10.5 (US・UH型) (US・UH Model)	
	20		98.1	176.5	353.0									4.070
	30		94.1	168.7	338.3									
	50		62.8	112.8	225.6									3.330



# BR-S Models

## 型式表示 Model Indication

ご注文に際しては、下記の様に型式を明記下さい。

When ordering, please specify the model as shown below

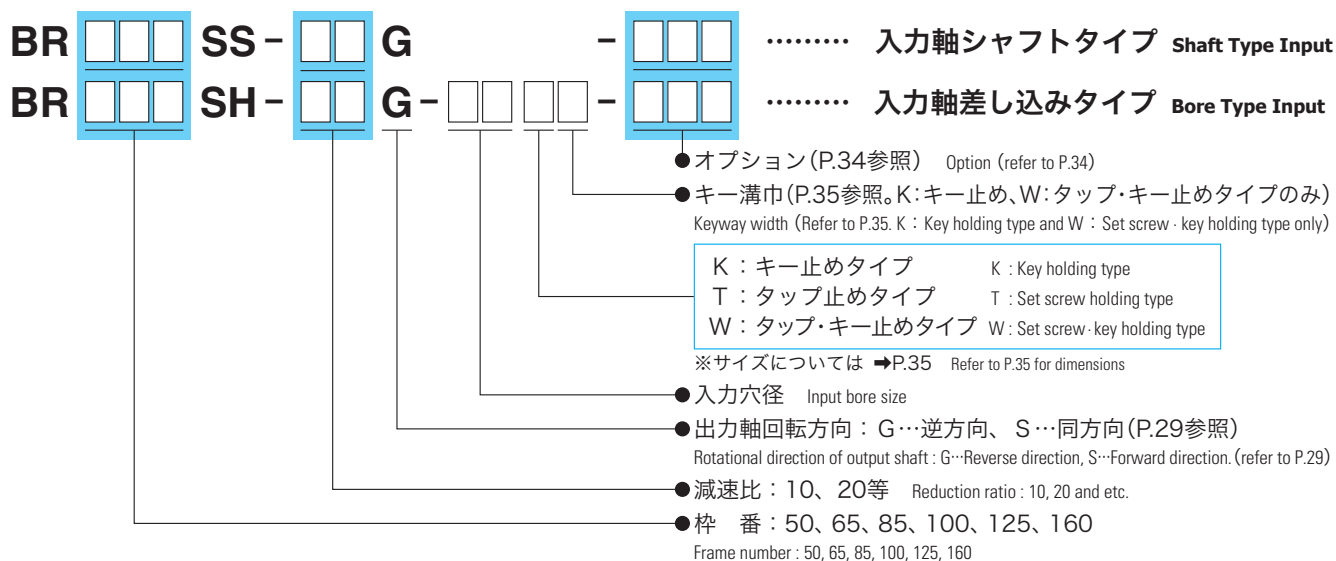

### 記入例 Examples

**BR65SS-10G**.....型式BR65/入力軸シャフトタイプ/減速比10

Model BR65 / input shaft type / reduction ratio 10

**BR100SH-20G-14K5**...型式BR100/入力軸差し込みタイプ/減速比20/入力穴径14/キー止めタイプ/キー溝巾5

Model BR100 / bore input type / reduction ratio 20 / 14mm input bore / 5mm keyway width

**BR85SH-30S-8T**.....型式BR85/入力軸差し込みタイプ/減速比30/入力穴径8/タップ止めタイプ

Model BR85 / bore input type / reduction ratio 30 / 8mm input bore / set screw holding type

### BR-Sユニット寸法表 Table of BR-S Series Dimensions

型式 Model	A	B	C	d	D	E	F	G	H	I	J	K	L	M	N	O	P	Q	R	S	t	T	KY <sub>1</sub>	KY <sub>2</sub>
<b>BR50SS BR50SH</b>	50	38	15	8	10	20	19	15	—	30	40	30	92	44	4	M5 深さ8 Depth 8	6	M3 深さ8 Depth 8	19	2	6	15	3×1.8	丸 Round
<b>BR65SS BR65SH</b>	66	51	15	8	12	30	21	20	12	42	56	42	117	56	6	M4 深さ10 Depth 10	6	M4 深さ11 Depth 11	28	2	6.3	17	4×2.5	3×1.8
<b>BR85SS BR85SH</b>	86	50	25	10	18	35	25	25	15	55	70	55	135	75	6	M5 深さ10 Depth 10	6	M5 深さ11 Depth 11	33	2	7.5	21	5×3.0	3×1.8
<b>BR100SS BR100SH</b>	100	56	33	12	20	40	30	25	20	65	84	65	159	89	6	M6 深さ12 Depth 12	6	M5 深さ11 Depth 11	38	2	9	27	5×3.0	4×2.5
<b>BR125SS BR125SH</b>	125	65	29	16	30	50	35	30	20	80	100	80	179	113	6	M8 深さ15 Depth 15	6	M6 深さ15 Depth 15	48	2	10	32	7×4.0	5×3.0
<b>BR160SS BR160SH</b>	160	87	45	25	40	60	49	40	30	100	135	100	241	144	6	M10 深さ20 Depth 20	6	M8 深さ16 Depth 16	58	5	13	42	10×5.0	7×4.0

**BR-S**

**入力軸シャフトタイプ / SS型 Shaft type input / SS type : Shaft in, Shaft out**

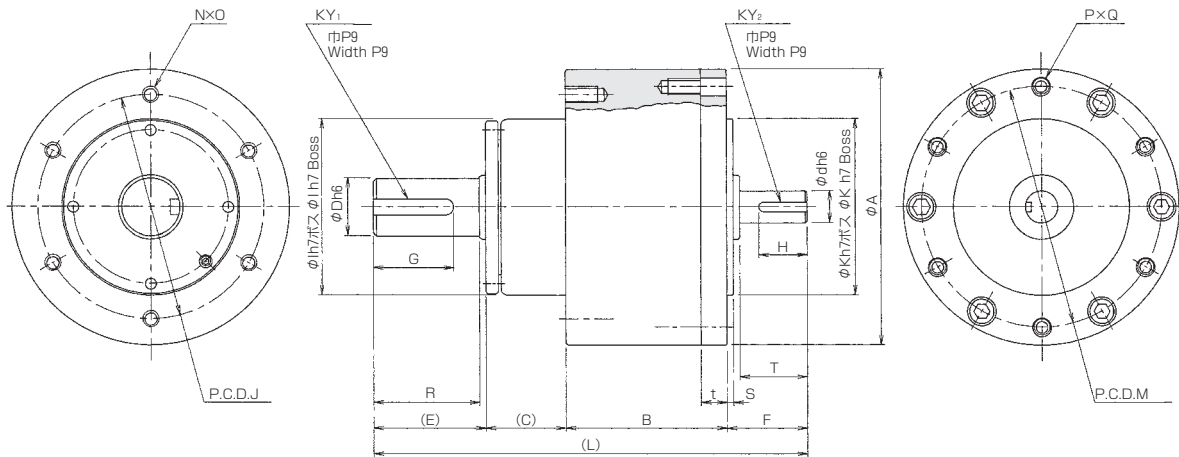

**入力軸差し込みタイプ / SH型 Bore type input / SH type : Bore in, Shaft out**

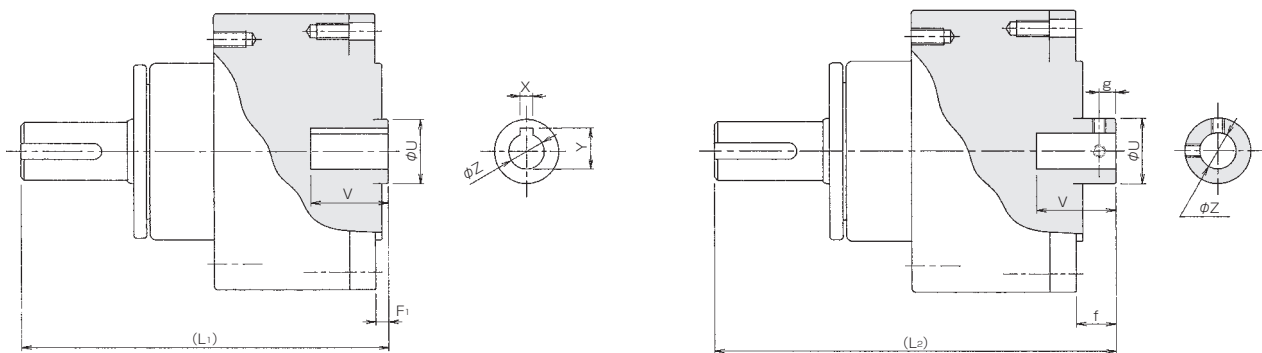

キー止めタイプ Key holding type

タップ止めタイプ Set screw holding type

**穴入力型 Bore Type Input**

型式 Model	L <sub>1</sub>	L <sub>2</sub>	U	V	g	f	F <sub>1</sub>	X · Y · Z	max Z
BR50SS BR50SH	77	83	12	20	4.0	10	4	P.35参照 Refer to P.35	7
BR65SS BR65SH	100	106	15	23	4.0	10	4		8
BR85SS BR85SH	114	122	20	24	5.0	12	4		11
BR100SS BR100SH	132	141	25	28	5.0	12	3		14
BR125SS BR125SH	147	156	30	30	Wタイプ P.35参照 W type Refer to P.35		3		20
BR160SS BR160SH	199	208	40	40			7		28





# BR-U Models

## 型式表示 Model Indication

ご注文に際しては、下記の様に型式を明記下さい。

When ordering, please specify the model as shown below

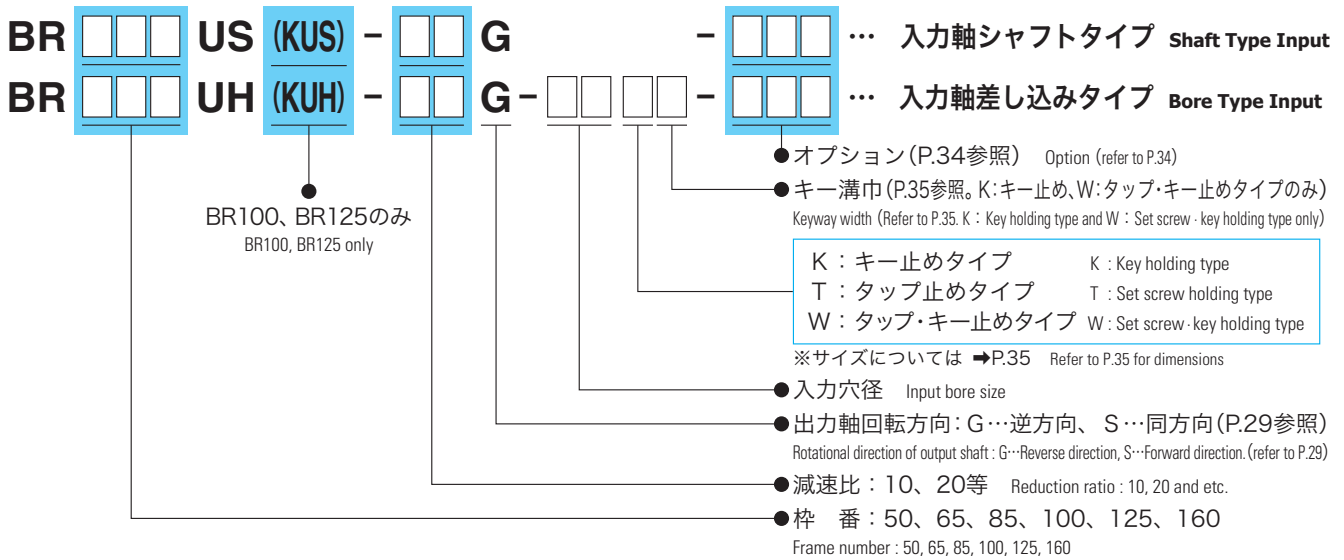

## 記入例 Examples

**BR65US-10G**.....型式BR65/入力軸シャフトタイプ/減速比10  
Model BR65/input shaft type/reduction ratio 10

**BR100KUH-20G-14K5**...型式BR100/入力軸差し込みタイプ/減速比20/入力穴径14/キー止めタイプ/キー溝巾5  
Model BR100/bore input type/reduction ratio 20/14mm input bore/5mm keyway width

**BR85UH-30S-8T**.....型式BR85/入力軸差し込みタイプ/減速比30/入力穴径8/タップ止めタイプ  
Model BR85/bore input type/reduction ratio 30/8mm input bore/set screw holding type

## BR-Uユニット寸法表 Table of BR-U Series Dimensions

型式 Model	A	B	C	d	D	E	F <sub>1</sub>	F <sub>2</sub>	G	H	I	J	K	L	M	N	O	P	Q	R	S	t	a	b	KY
BR50US BR50UH	50	33	5	8	20	10	4	19	10	—	38	15	30	62	44	6	M4 深さ8 Depth 8	6	M3 深さ8 Depth 8	15	2	6	4	M3 深さ7 Depth 7	丸 Round
BR65US BR65UH	66	39	5	8	30	10	4	21	15	12	48	23	42	70	56	6	M4 深さ10 Depth 10	6	M4 深さ11 Depth 11	17	2	6.3	4	M4 深さ8 Depth 8	3×1.8
BR85US BR85UH	86	45	5	10	40	10	4	25	20	15	67	30	55	80	75	6	M5 深さ10 Depth 10	6	M5 深さ11 Depth 11	20	2	7.5	4	M5 深さ10 Depth 10	3×1.8
BR100KUS BR100KUH	100	56	5	12	50	10	3	30	25	20	80	40	65	96	89	6	M5 深さ10 Depth 10	6	M5 深さ11 Depth 11	24	2	9	4	M6 深さ12 Depth 12	4×2.5
BR125KUS BR125KUH	125	60	6	16	65	10	3	35	30	20	100	50	80	105	113	6	M6 深さ12 Depth 12	6	M6 深さ12 Depth 12	18	2	10	4	M8 深さ16 Depth 16	5×3.0
BR160US BR160UH	160	75	7	25	80	17	7	49	40	30	126	65	100	141	144	6	M8 深さ16 Depth 16	6	M8 深さ16 Depth 16	35	5	13	6	M8 深さ16 Depth 16	7×4.0

## BR-U

## 入力軸シャフトタイプ / US(KUS)型 Shaft type input / US(KUS) type : Shaft in, Flange out

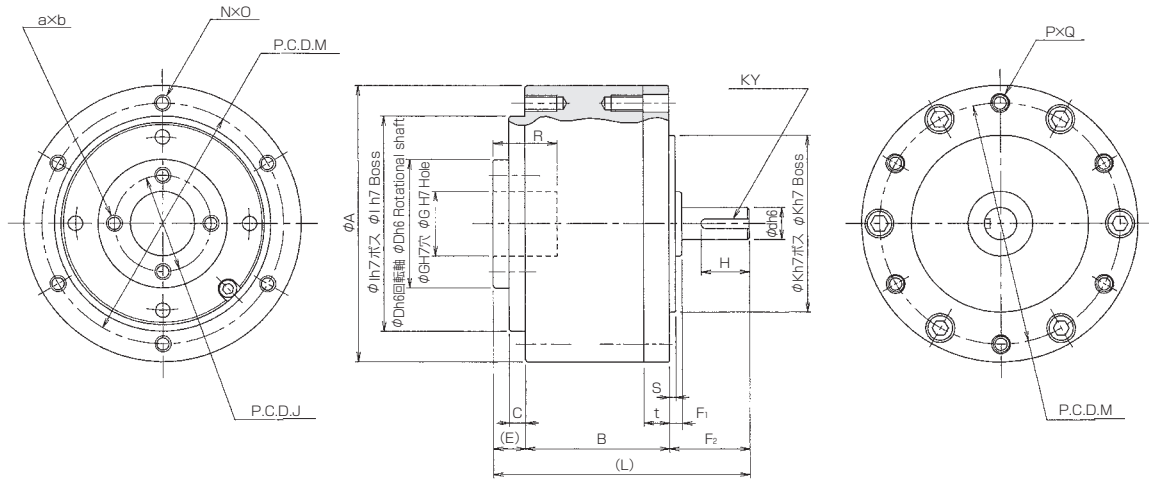

## 入力軸差し込みタイプ / UH(KUH)型 Bore type input / UH(KUH) type : Bore in, Flange out

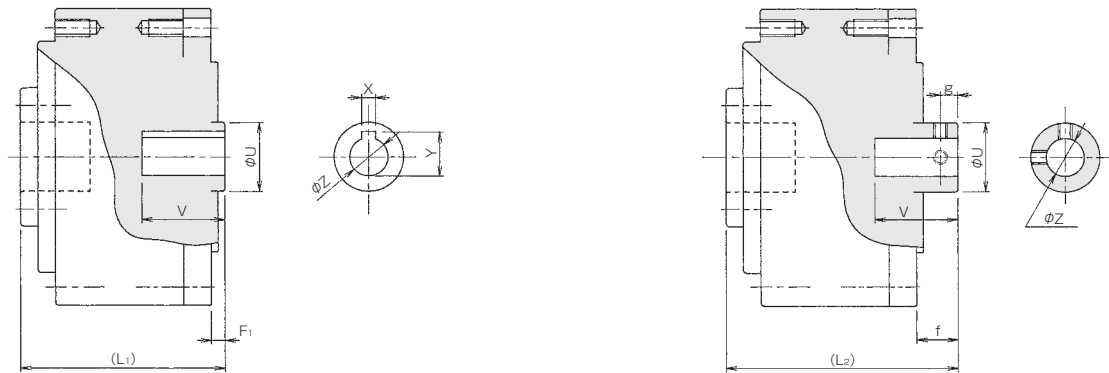

キー止めタイプ  
Key holding type

タップ止めタイプ  
Set screw holding type

## 穴入力型 Bore Type Input

型式 Model	L <sub>1</sub>	L <sub>2</sub>	U	V	g	f	F <sub>1</sub>	X · Y · Z	max Z
BR50US BR50UH	47	53	12	20	4.0	10	4	P.35参照 Refer to P.35	7
BR65US BR65UH	53	59	15	23	4.0	10	4		8
BR85US BR85UH	59	67	20	24	5.0	12	4		11
BR100KUS BR100KUH	69	78	25	28	5.0	12	3		14
BR125KUS BR125KUH	73	82	30	30	Wタイプ P.35参照 W type Refer to P.35		3		20
BR160US BR160UH	99	108	40	40			7		28

オプション項目 Optional Items

標準型番 -

Standard model



- **その他オプション記号**  
Other option code
- **入力軸オプション記号**  
Input shaft option code
- **出力軸のオプション記号**  
Output shaft option code

記入例 Examples

**BR85SH-10G-8K3-1EX**

型式BR85/S型出力軸キー溝無し/H型入力軸穴径φ8/キー溝巾3/入力軸キー溝巾公差: Js9/ハウジング貫通穴

Model BR85/S type output shaft keyless/H type input shaft with bore 8/3mm keyway width/tolerance of input shaft keyway width : Js9/drill-through-hole housing

出力軸オプション記号 Output shaft option code

記号 Code	内容 Content	適用 Application
無記号 No code	オプション設定無し No option setting	
1	キー溝無し Keyless	BR-SS, SH
2	キー溝、先端タップ付き Keyway, tip tap	
3	Dカット "D"-cut	
4	Dカット、先端タップ付き "D"-cut, tip tap	BR-US, UH
5	キー溝付き、溝巾公差P9 Keyway, keyway tolerance P9	
6	キー溝付き、溝巾公差Js9 Keyway, keyway tolerance Js9	

入力軸オプション記号 Input shaft option code

記号 Code	内容 Content	適用 Application
無記号 No code	オプション設定無し No option setting	
A	キー溝無し Keyless	BR-SS, US
B	キー溝、先端タップ付き Keyway, tip tap	
C	Dカット "D"-cut	
D	Dカット、先端タップ付き "D"-cut, tip tap	
G	カップリング用ショートタイプ(カップリング別) Short-length type for a coupling (A coupling sold separately)	
CL	オルダムカップリング付(P.36及びP.38-39参照) With Oldham coupling (Refer to P.36 and P.38-39)	BR-SH, UH
E	キー溝、溝巾公差Js9 Keyway, keyway tolerance Js9	

その他オプション記号 Other option code

記号 Code	内容 Content	適用 Application
無記号 No code	オプション設定無し No option setting	
X	ハウジング貫通穴 Drill-thru-hole housing	BR-SS, SH, US, UH

## H型入力軸オプション(穴入力型) H-Type Input Shaft Option (Bore Input Type)

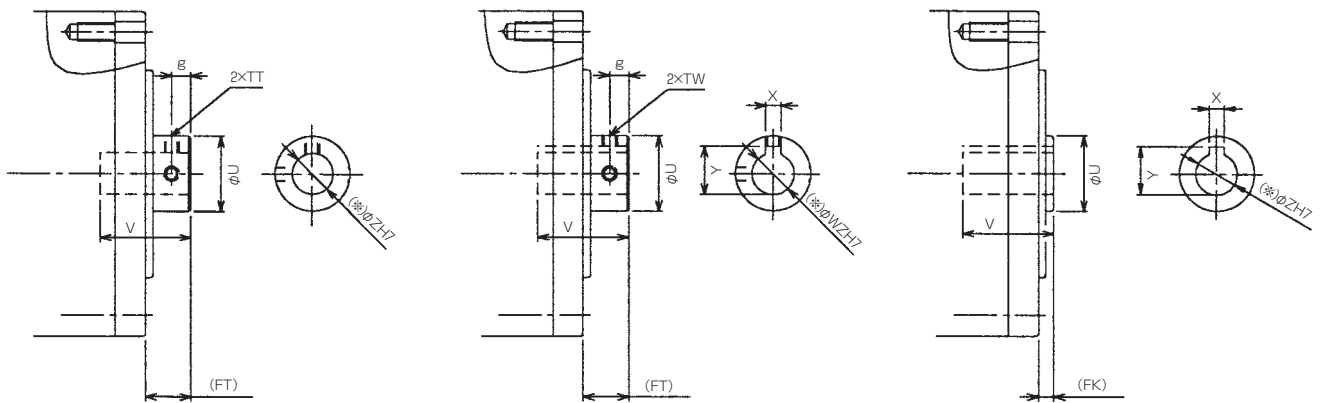
**T** タップ止めタイプ  
Set screw holding type

(注)タップTTは、穴径によって下記表のようになります。  
(Note) Tap sizes are specified in the table below according to bore sizes.

入力軸穴径 Input shaft bore size	タップサイズ Tap size
$\phi Z$	TT
5~6.9	M3×0.5
7~7.9	M4×0.7
8~14.0	M5×0.8

(注)タップ止めタイプは、BR125・160の設定がございません。  
(Note) Set screw holding type is not available in BR125・160.

**W** タップ・キー止めタイプ  
Set screw · key holding type

(注)タップTWは、キー巾によって下記表のようになります。  
(Note) Tap sizes are specified in the table below according key width.

キー巾 Key width	タップサイズ Tap size
X	TW
2	M3×0.5
3	M3×0.5
4	M4×0.7
5	M5×0.8
6	M5×0.8
8	M5×0.8

**K** キー止めタイプ  
Key holding type

## 穴入力型寸法 Table for Bore Input Type Dimensions

各入力タイプの対応穴径については別表(p.36 入力軸穴径対応表)をご確認ください。

Please refer to P.36 "Input Hole Diameter Correspondence Table" for the input hole diameters of each holding type.

型式 Model	U	V	g	FK	FT	max Z	min Z	max WZ
BR50	12	20	4.0	4	10	7	5	-
BR65	15	23	4.0	4	10	8	6	7
BR85	20	24	5.0	4	12	11	7	9
BR100	25	28	5.0	3	12	14	9	11
BR125	30	30	5.0	3	12	20	10	14
BR160	40	40	5.5	7	16	28	14	22

## キー溝寸法表 Table of Keyway Dimensions

\*単位: mm Unit: mm

キー溝巾の寸法 Keyway width		キー溝巾オプション Keyway width option	キー溝深さ Yの寸法(軸穴径Z+t) Keyway depth "Y" dimension (Bore size "Z" + t)		(注) 適応する軸径 Corresponding shaft size (Note)
Xの基準寸法 Reference Dim. of X	許容差(P9) Tolerance (P9)	許容差(Js9) Tolerance (Js9)	tの基準寸法 Reference Dim. of t	許容差 Tolerance	
2	-0.006 -0.031	±0.0125	1.0	+0.1 0	6~8
3			1.4		8~10
4	-0.012 -0.042	±0.015	1.8		10~12
5			2.3		12~17
6			2.8		17~22
8	-0.015 -0.051	±0.018	3.3	+0.2 0	22~30

(注) 適応する軸径は、キーの強さに対応するトルクに適應するものとする。(Note) The corresponding shaft sizes are subject to the corresponding torque to the strength of the keys.

**入力軸穴径対応表**

キー止め(記号:K) / タップ止め(記号:T) ※BR125・160はKタイプのみ

Key holding "OP : K" / Set screw holding "OP : T" ※BR125-160 are key holding type only.

型式 Model	入力軸穴径 φZ Input hole diameter																													
	5	6	7	8	9	10	11	12	13	14	15	16	17	18	19	20	21	22	23	24	25	26	27	28	29	30				
BR50	●	●	●																											
BR65		●	●	●																										
BR85			●	●	●	●	●																							
BR100					●	●	●	●				●																		
BR125						●	●	●			●		●			●	●													
BR160											●	●			●	●		●		●	●			●			●			

キー・タップ止め(記号:W) ※BR50は設定なし

Set screw・Key holding "OP : W" ※BR50 is not setting OP : W

型式 Model	入力軸穴径 φWZ Input hole diameter																													
	5	6	7	8	9	10	11	12	13	14	15	16	17	18	19	20	21	22	23	24	25	26	27	28	29	30				
BR65		●	●																											
BR85			●	●	●	●																								
BR100					●	●	●																							
BR125						●	●	●			●																			
BR160											●	●			●	●		●												

オルダムカップリング方式(記号:CL) ※詳細についてはP.38-39をご参照ください。

Oldham coupling method "OP : CL". ※Please refer to P. 38 to 39 for the oldham coupling details.

型式 Model	オルダムカップリング入力穴径 φZ Input hole diameter for Aldham coupling																											
	3	4	5	6	7	8	9	9.5	10	11	12	13	14	15	16	17	18	19	20	22	24	25	28	30	35	30		
BR50	●	●	●	●	●	●	●	●	●	●																		
BR65			●	●	●	●	●	●	●	●																		
BR85			●	●	●	●	●	●	●	●																		
BR100				●		●	●	●	●	●	●	●	●	●	●	●	●	●	●									
BR125				●		●	●	●	●	●	●	●	●	●	●	●	●	●	●									
BR160						●			●		●	●	●	●	●	●	●	●	●	●	●	●						

その他穴径をご希望の方は、弊社へご相談ください。 If you would like other input hole diameters, please contact us.

**S型入力軸オプション(軸入力型) S-Type Input Shaft Option (Shaft Input Type)**

オプション記号B(先端タップ付き)  
Option code B (Tip tap)

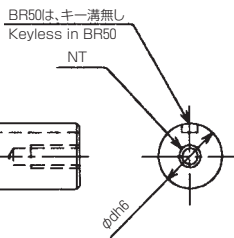

型式 Model	NT
BR50	M3 深サ6 M3 Depth 6
BR65	M3 深サ6 M3 Depth 6
BR85	M4 深サ8 M4 Depth 8
BR100	M5 深サ10 M5 Depth 10
BR125	M6 深サ12 M6 Depth 12
BR160	M6 深サ12 M6 Depth 12

オプション記号C(Dカット)  
Option code C ("D" cut type)

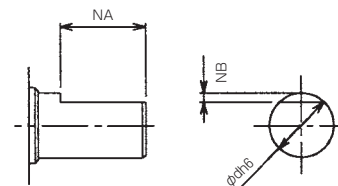

型式 Model	NA	NB
BR50	10	1
BR65	12	1
BR85	15	1
BR100	-	-
BR125	-	-
BR160	-	-

オプション記号D  
(Dカット・先端タップ付き)  
Option code D  
("D" cut・tip tap)

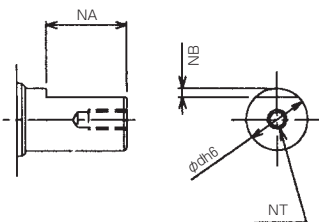

型式 Model	NT	NA	NB
BR50	M3 深サ6 M3 Depth 6	10	1
BR65	M3 深サ6 M3 Depth 6	12	1
BR85	M4 深サ8 M4 Depth 8	15	1
BR100	-	-	-
BR125	-	-	-
BR160	-	-	-

オプション記号G  
(カップリング用ショートタイプ)  
Option code G  
(Short type for couplings)

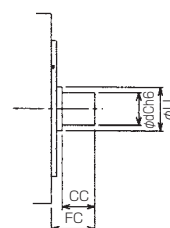

型式 Model	dC	U	CC	FC
BR50	8	12	7	11
BR65	8	15	12	16
BR85	10	20	12	16
BR100	12	25	15	18
BR125	16	30	15	18
BR160	24	40	15	22

出力軸オプション Option of Output Shaft

オプション記号2(先端タップ付き)  
Option code 2(Tip tap)

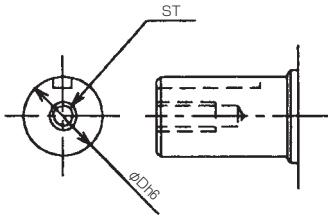

型式 Model	ST
BR50	M4 深サ8 M4 Depth 8
BR65	M5 深サ10 M5 Depth 10
BR85	M6 深サ12 M6 Depth 12
BR100	M6 深サ12 M6 Depth 12
BR125	M8 深サ16 M8 Depth 16
BR160	M8 深サ16 M8 Depth 16

オプション記号3(Dカット)  
Option code 3("D"cut type)

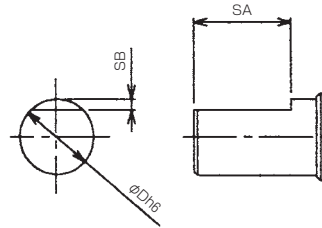

型式 Model	SA	SB
BR50	15	1
BR65	20	1
BR85	25	1
BR100	-	-
BR125	-	-
BR160	-	-

オプション記号4  
(Dカット・先端タップ付き)  
Option code 4  
("D"cut・tip tap)

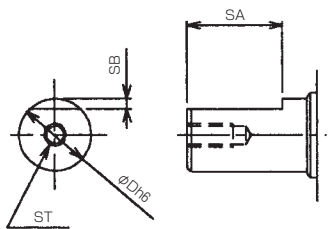

型式 Model	ST	SA	SB
BR50	M4 深サ8 M4 Depth 8	15	1
BR65	M5 深サ10 M5 Depth 10	20	1
BR85	M6 深サ12 M6 Depth 12	25	1
BR100	-	-	-
BR125	-	-	-
BR160	-	-	-

オプション記号5(6)  
(キー溝付き・溝巾公差P9(Js9))  
Option code 5(6)  
(Keyway・keyway tolerance P9(Js9))

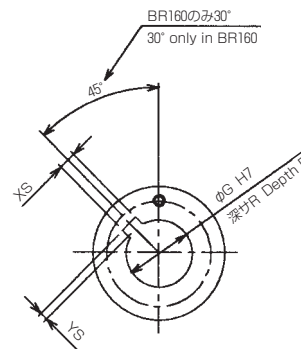

型式 Model	XS	YS
BR50	4P9(Js9)	1.8 $^{+0.1}_0$
BR65	5P9(Js9)	2.3 $^{+0.1}_0$
BR85	6P9(Js9)	2.8 $^{+0.1}_0$
BR100	8P9(Js9)	3.3 $^{+0.2}_0$
BR125	10P9(Js9)	3.3 $^{+0.2}_0$
BR160	12P9(Js9)	3.3 $^{+0.2}_0$

その他オプション Other Options

オプション記号X(ハウジング貫通穴) Option code X(Drill-thru-hole housing)

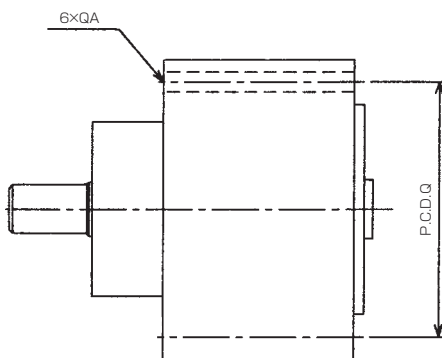

Sモデル S model

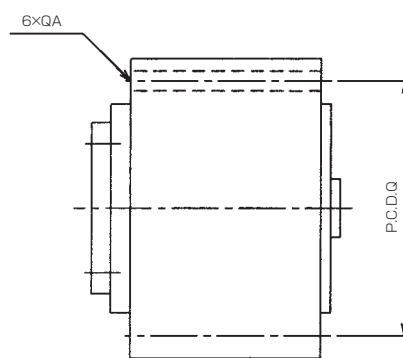

Uモデル U Model

型式 Model	QA	Q
BR50	-	-
BR65	4.3	56
BR85	5.3	75
BR100	5.3	89
BR125	6.3	113
BR160	8.5	144

オルダムカップリング Oldham Coupling

オルダムカップリング方式 Oldham coupling method

減速機とモータの連結 Connecting Ball Reducer to Motor

減速機とモータの連結は簡単なようですが、微少の誤差が悪影響を及ぼすことがあります。特にモータ軸を減速機に直接挿入するものでは、芯ずれ、穴やキー溝の精度などが減速機の性能、モータの性能にまで影響します。又、組み立てや取り外し等のメンテナンス性もよくありません。

It may seem easy to mount the motor to the ball reducer, but you must heed to errors which can adversely affect on the performance. Especially in the type in which the motor shaft is directly inserted to the ball reducer, an axial misalignment, a key and keyhole accuracy affect not only on the ball reducer but also on the motor itself. This reflects on a poor maintenance when re-assembling the motor to the ball reducer after disassembled them.

オルダムカップリング Oldham Coupling

上記の様な欠点を解決する方法として、オルダムカップリング方式(図1)を標準品に追加致しました。カップリングは標準付属品です。(下枠参照)但し、モータはユーザー様のご選定となり、その形式も多様であることから、モータ側カップリングの内径加工、及び取り付け用のフランジ(減速機とモータを連結するための長フランジ)はユーザー様でお手配頂くことになります。もし、ご指定であれば弊社で実費にて製作、取り付け致しますので、ご用命下さい。ユーザー様でお作りになるときは、参考図をご覧の上、寸法を決めてお作り下さい。(図2)

As an instrument to overcome above drawbacks, added is Oldham's coupling (Fig. 1) to standard product. Coupling stands as standard accessory (refer to underside frame). Since motor is left to users' option and there are a wide variety motors, machining inner diameter of coupling and mounting flange (a long flange connecting motor to speed reducer) are arranged at users' side. If customers wish to have arranged at our side, contact us so that we will machine and mount them at customers' expense. If machined and mounted at users' side, determine dimensional sizes with reference to drawing (Fig. 2)

オルダムカップリング内径加工の注意

Notice in machining the bore of the Oldham coupling.

スリ割に板をはさみ込み旋盤のコレットで締めつけて下さい。ダイヤルゲージなどを当て振れがないことを確認して下さい。

お申しつけがあれば加工して納入致します。(要実費)

Insert a plate into the slit and tighten the plate by the collet of the lathe. Avoid the deflection and check no deflection by a dial gauge.

Upon customer's request we can provide the finished coupling at cost.

型式表示 Model Indication

オルダムカップリング付のご注文に際しては、減速比の後にCLと穴径(穴加工付)を付して下さい。穴径なき場合は最少穴径納入となります。

When ordering the ball reducer with a Oldham coupling, please specify CL and the bore size following the reduction ratio. In case of no bore size indication, the unit will be supplied at the minimum bore size.

記入例 Examples

BR65US-10G-CL8

型式BR65/出力軸フランジタイプ/入力軸シャフトタイプ(カップリング入力穴φ8加工付)

Model BR65/Flange type Output shaft/Shaft type Coupling input bore φ8 finish

オルダムカップリング(図1)

Oldham coupling (Figure. 1)

ボスとスペーサーは各型番、どの軸径に対しても互換性があります。

Bosses and spacers are interchangeable in the bore size to any models.

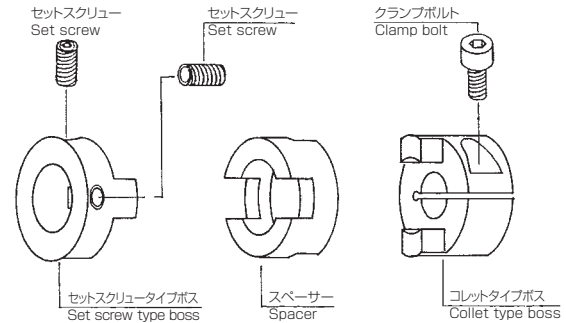

フランジの形状・寸法(図2)

Shape and dimensions of flange (Figure. 2)

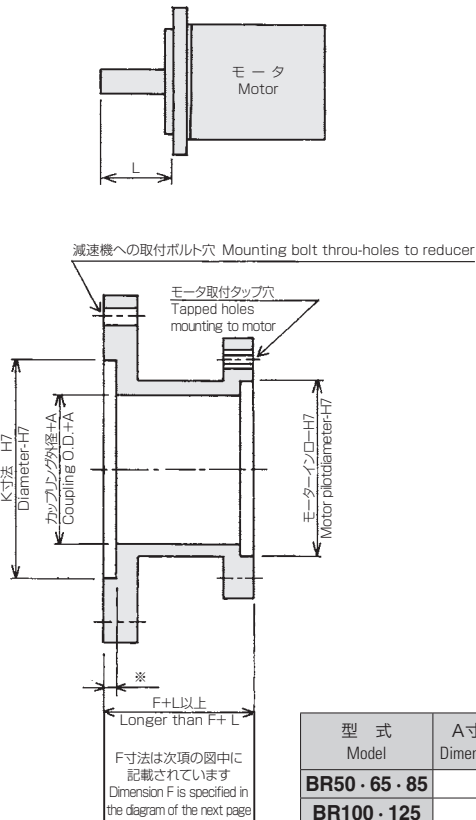

※BR50~BR125=3 BR160=6

型式 Model	A寸法(min) Dimension A (min)
BR50・65・85	—
BR100・125	4.5
BR160	5.3

各方式の寸法表 Dimension List of Each Input Method

※対応穴径  $\phi Z$  については別表(p.36 入力軸穴径対応表)をご確認ください。

※For the corresponding input hole diameter  $\phi Z$ , please refer to P.36 "Input hole diameter table about Oldham coupling method".

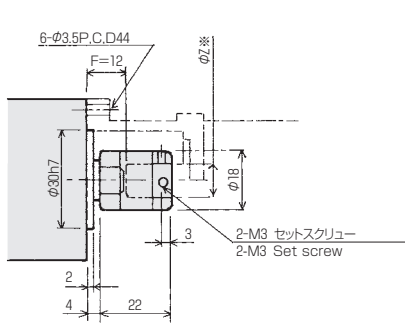

BR50SS BR50US

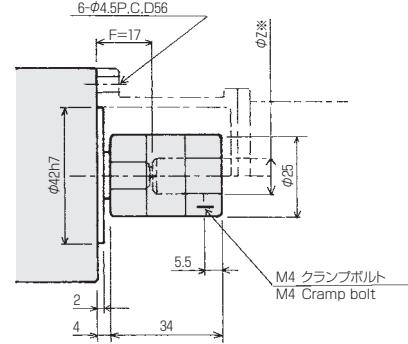

BR65SS BR65US

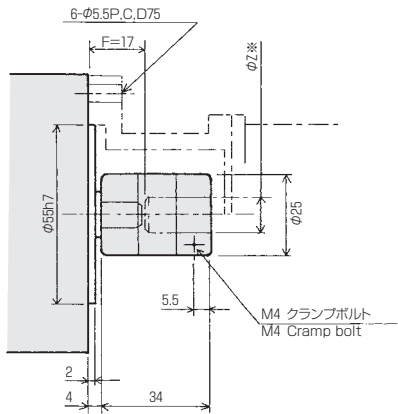

BR85SS BR85US

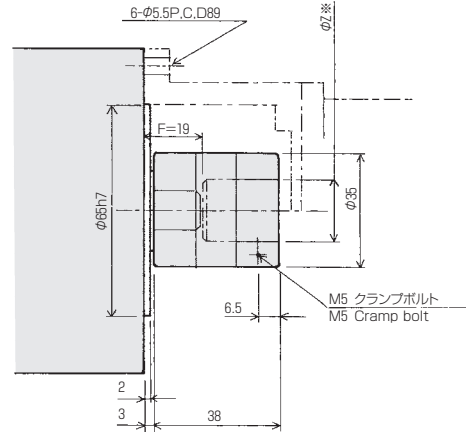

BR100SS BR100KUS

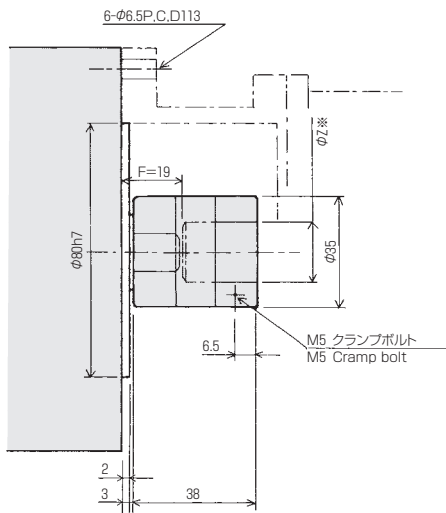

BR125SS BR125KUS

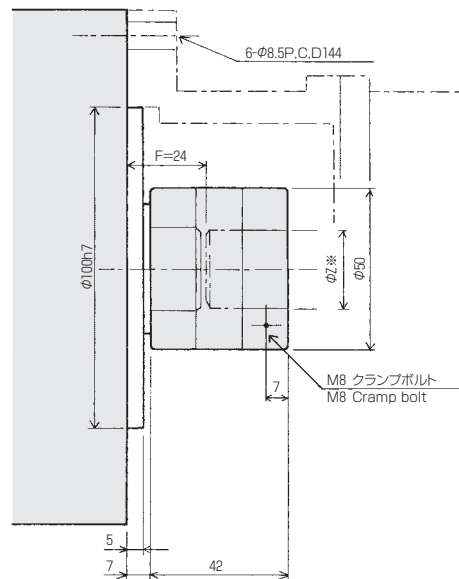

BR160SS BR160US



ボ ー ル 減 速 機

# 技 術 資 料

Technical Documents of Ball Reducer

角度伝達精度 Angular Transmission Accuracy

角度伝達精度は、入力軸側に、任意の回転角(θ1)を与えた時の出力軸の理論上回転する回転角度(θ2)と実際に回転した角度(θ'2)との差をいい、出力軸1回転で生じる最大差を角度伝達精度(θer)と表します。

The angular transmission accuracy generally refers to the difference between the angle of theoretical rotation (θ2) of the output shaft when any angle of rotation (θ1) is applied to the input shaft side and the angle of the actual rotation (θ'2), and particularly refers to the maximum difference caused when the output shaft makes a 360-degree roll (θer).

$$\theta_{er} = \theta'_2 - \theta_2 = \theta'_2 - \theta_1 / R \quad (R : \text{減速比 Reduction ratio})$$

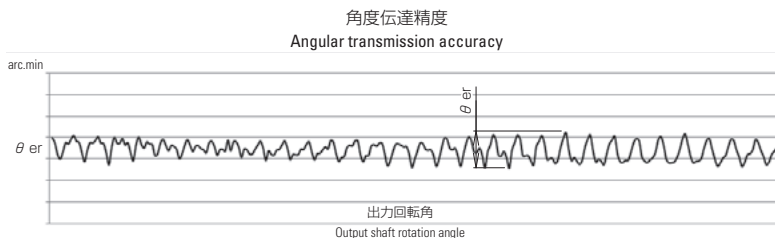

JFR

型 式 Model	減速比 Reduction ratio	角度伝達精度 Angular transmitting accuracy arc · min
JFR60	1/10.5	5
	1/15	
	1/20	
	1/30	
JFR90	1/10.5	4
	1/15	
	1/20	
	1/30	
	1/40	
JFR120	1/10.5	4
	1/15	
	1/20	
	1/30	
	1/40	

BR

型 式 Model	減速比 Standard reduction ratio	角度伝達精度 Angular transmitting accuracy arc · min
BR50	1/10	6.5
	1/15	
	1/18	
BR65	1/10	5
	1/15	
	1/20	
BR85	1/10	5
	1/15	
	1/20	
	1/30	
BR100	1/10	4
	1/15	
	1/20	
	1/30	
	1/40	
BR125	1/10	4
	1/15	
	1/20	
	1/30	
	1/50	
BR160	1/10	4
	1/15	
	1/20	
	1/50	

SFP

型 式 Model	減速比 Reduction ratio	角度伝達精度 Angular transmitting accuracy arc · min
SFP70	1/8	7
	1/10	
	1/20	
	1/30	
SFP85	1/10	4
	1/20	
	1/30	
	1/40	
SFP100	1/10	3
	1/20	
	1/30	
	1/40	
SFP125	1/10	3
	1/20	
	1/30	
	1/40	
	1/50	

剛性 Rigidity

入力軸を固定し、出力軸にトルクを加えると、出力軸はトルクにほぼ比例したねじれを生じ、ヒステリシスカーブを描きます。これを定量的に表現する為に、定格トルクの3%と100%の点をつなぐ折れ線グラフを考え、

- ・バネ定数 =  $b/a$
- ・ロストモーション：定格トルクの±3%でのヒステリシスカーブの中間点のねじれ角と定義します。

When the input shaft is fixed and the output shaft is torqued, the output shaft generates torsion in near proportion to the torque, drawing a hysteresis curve. To express this quantitatively, a line graph connecting the 3% point of the rated torque to the 100% point of the rated torque, and the following are defined :

- Spring coefficient =  $b/a$
- Lost motion : The torsion angle of the intermediate point of the hysteresis curve at ±3% of the rated torque

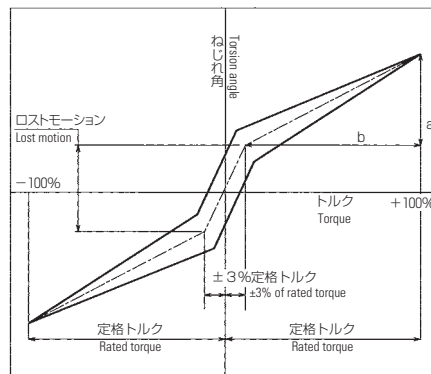

JFR

型式 Model	減速比 Reduction ratio	ロストモーション Lost motion arc · min	バネ定数 $b/a$ Spring constant $\times 10^4 N \cdot m/rad$
JFR60	1/10.5	4	0.21
	1/15		0.23
	1/20		0.24
	1/30		0.25
JFR90	1/10.5	3	0.50
	1/15		0.51
	1/20		0.55
	1/30		0.61
	1/40		0.66
JFR120	1/10.5	3	1.24
	1/15		1.32
	1/20		1.40
	1/30		1.57
	1/40		1.68

BR

型式 Model	減速比 Standard reduction ratio	ロストモーション Lost motion arc · min	バネ定数 $b/a$ Spring constant $\times 10^4 N \cdot m/rad$
BR50	1/10	6	0.044
	1/15		0.054
	1/18		0.061
BR65	1/10		0.044
	1/15		0.067
	1/20		0.081
BR85	1/10		0.12
	1/15		0.21
	1/20		0.27
BR100	1/30		0.29
	1/10		0.27
	1/20		0.47
	1/30		0.88
BR125	1/40		0.44
	1/10		0.64
	1/20	1.1	
	1/30	1.5	
	1/50	1.2	
BR160	1/10	1.4	
	1/20	2.2	
	1/30	2.6	
	1/50	1.9	

SFP

型式 Model	減速比 Reduction ratio	ロストモーション Lost motion arc · min	バネ定数 $b/a$ Spring constant $\times 10^4 N \cdot m/rad$
SFP70	1/8	3	0.10
	1/10		0.12
	1/20		0.15
	1/30		
SFP85	1/10		0.26
	1/20		0.32
	1/30		
	1/40		
SFP100	1/10		0.53
	1/20		0.65
	1/30		
	1/40		
SFP125	1/10	1.2	
	1/20	1.6	
	1/30		
	1/40		
	1/50		

(注)バネ定数値は、製品サンプルでの平均値を示します。  
(Note) Spring constant value is indicated by the average value of the product samples.

## 効率データ Efficiency Data

各型式の入力回転数別に負荷率(定格トルクに対する負荷の割合)に対する効率の値を示します。〈測定条件〉周囲温度25°C

The graphs show the ball reducer efficiency at each load factor (the ratio of the rated torque to the load) per the each rotation of the input shaft for each model. 〈Measurement condition〉 the ambient temperature 25°C

## JFR60型 効率 JFR 60 Type Efficiency

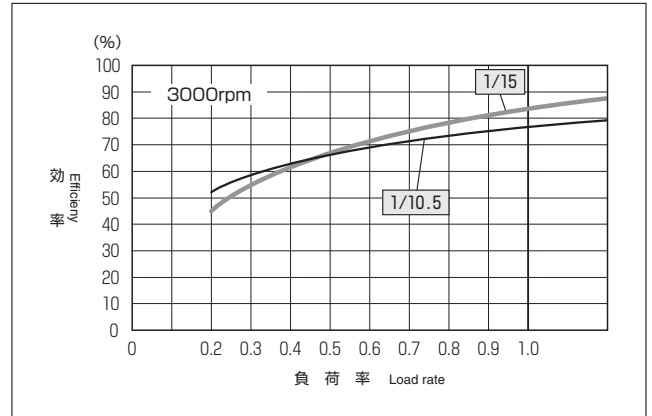
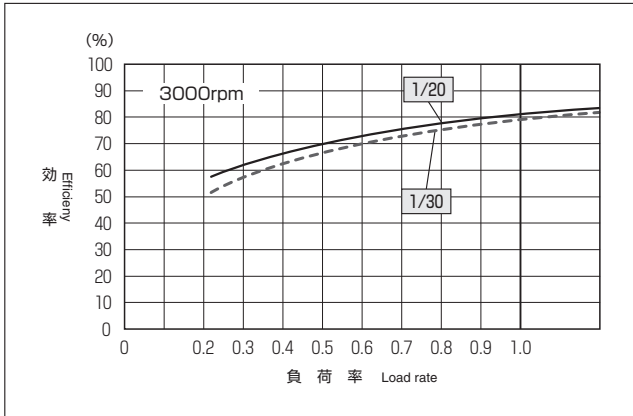

## JFR90型 効率 JFR 90 Type Efficiency

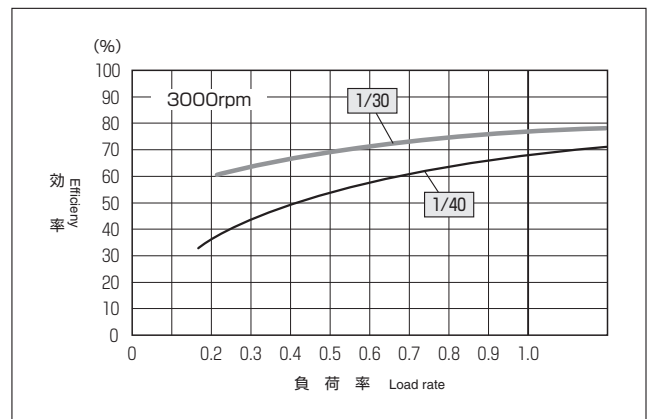
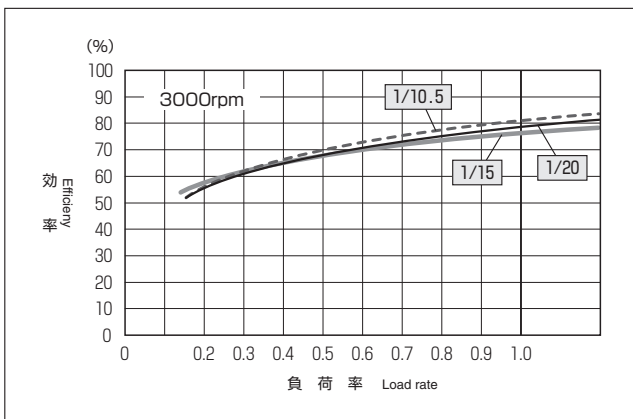

## JFR120型 効率 JFR 120 Type Efficiency

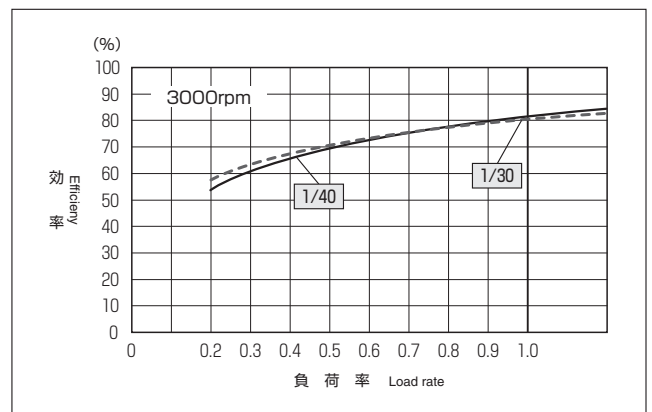
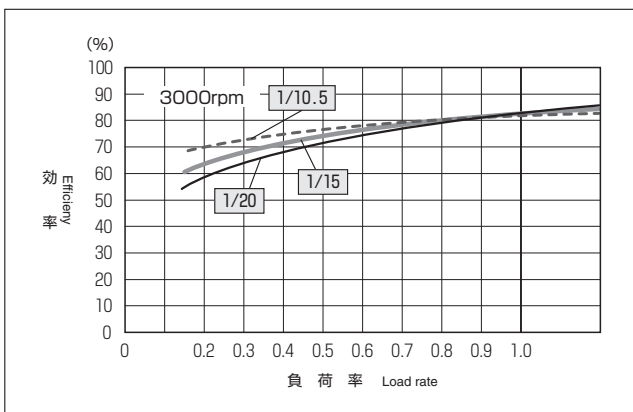

効率データ Efficiency Data

SFP70型 効率 SFP 70 Type Efficiency

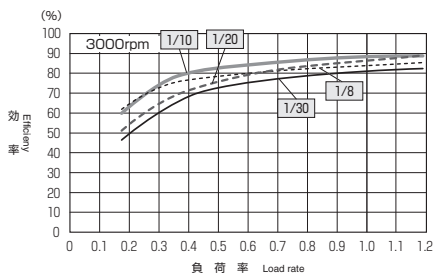

SFP85型 効率 SFP 85 Type Efficiency

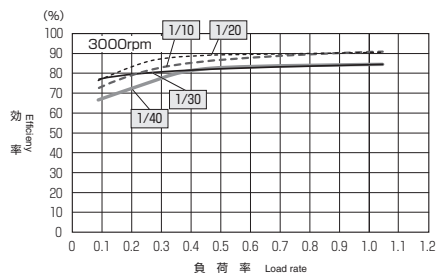

SFP100型 効率 SFP 100 Type Efficiency

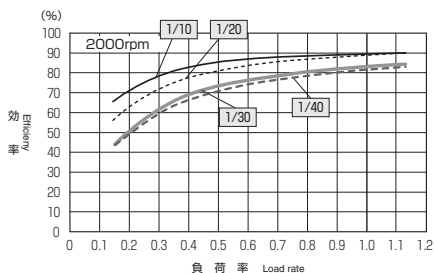

SFP125型 効率 SFP 125 Type Efficiency

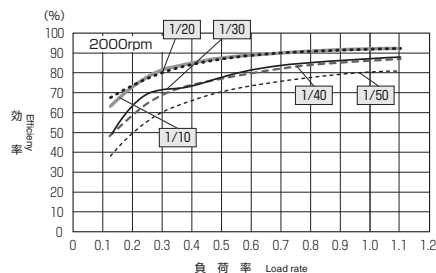

BR50型 効率 BR 50 Type Efficiency

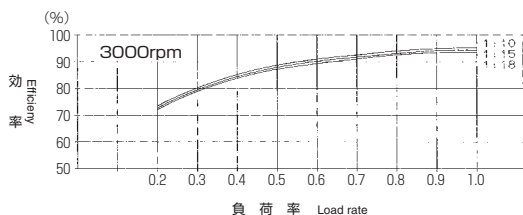

BR65型 効率 BR 65 Type Efficiency

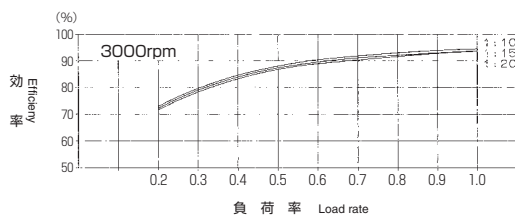

BR85型 効率 BR 85 Type Efficiency

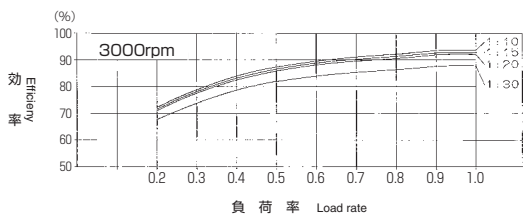

BR100型 効率 BR 100 Type Efficiency

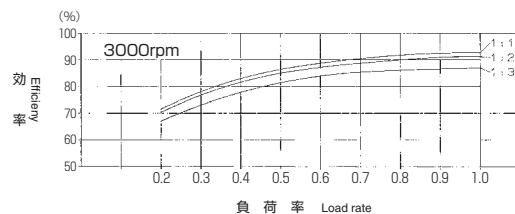

BR125型 効率 BR 125 Type Efficiency

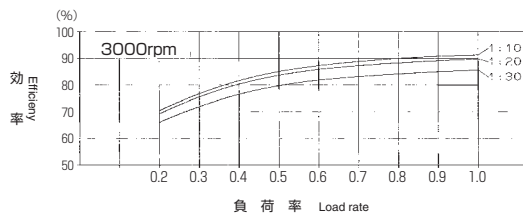

BR160型 効率 BR 160 Type Efficiency

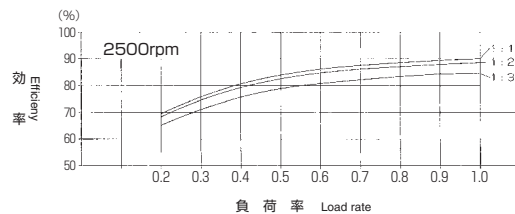

## 入力起動トルク Input Start-up Torque

### JFR

型式 Model	減速比 Reduction ratio	入力起動トルク Input start-up torque	
		N · m	kgf · cm
JFR60	1/10.5	0.167	1.7
	1/15		
	1/20		
	1/30		
JFR90	1/10.5	0.186	1.9
	1/15		
	1/20		
	1/30		
	1/40		
JFR120	1/10.5	0.216	2.2
	1/15		
	1/20		
	1/30		
	1/40		

### BR

型式 Model	減速比 Reduction ratio	入力起動トルク Input start-up torque	
		N · m	kgf · cm
BR50	10	0.031	0.32
	15		
	18		
BR65	10	0.041	0.42
	15		
	20		
BR85	10	0.062	0.63
	15		
	20		
	30		
BR100	10	0.144	1.47
	20		
	30		
	40		
BR125	10	0.176	1.80
	20		
	30		
	50		
BR160	10	0.370	3.78
	20		
	30		
	50		

SFP

型 式 Model	減速比 Reduction ratio	入力起動トルク Input start-up torque	
		N · m	kgf · cm
SFP70	1/8	0.082	0.84
	1/10		
	1/20		
	1/30		
SFP85	1/10	0.103	1.05
	1/20		
	1/30	0.093	0.95
	1/40	0.082	0.84
SFP100	1/10	0.154	1.58
	1/20		
	1/30	0.144	1.47
	1/40		
SFP125	1/10	0.206	2.10
	1/20		
	1/30	0.185	1.89
	1/40		
	1/50		

型番選定フローチャート Model No. Selection Flow Chart

使用条件からボール減速機の型番を選定します。  
The model No. of the ball reduction gear is selected according to the operating conditions.

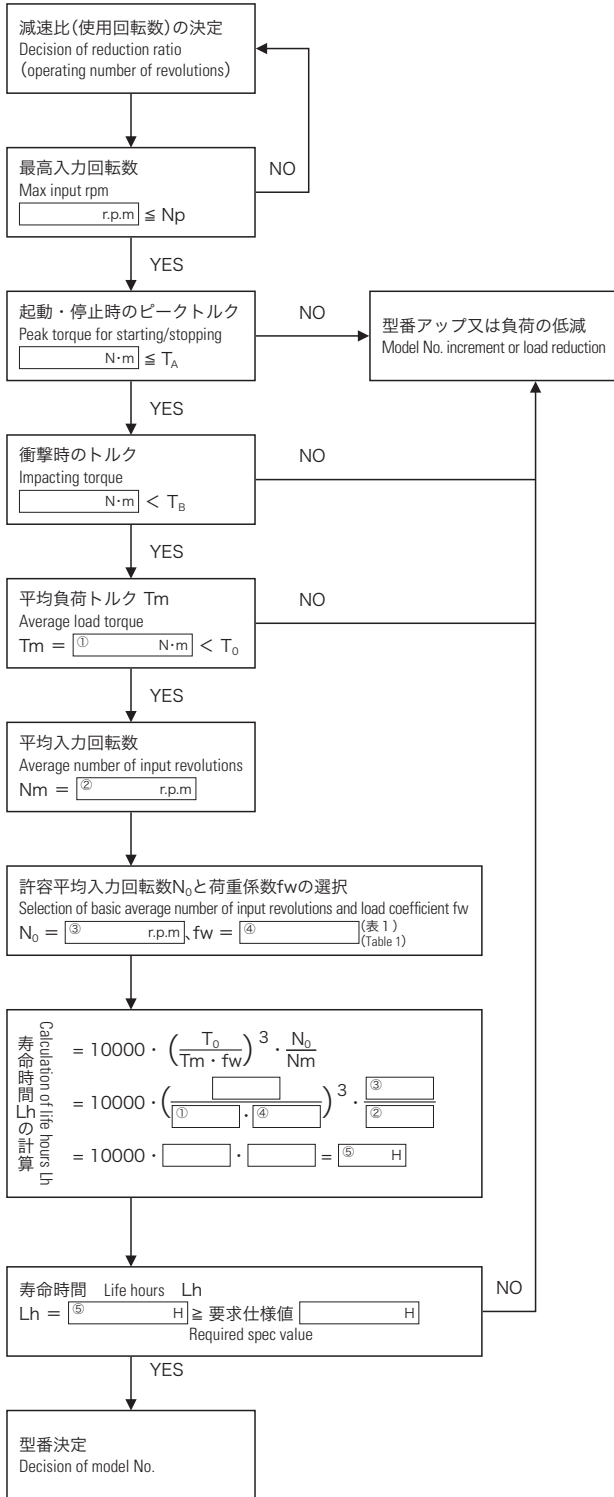

- Np : 最高入力回転数 (r.p.m)  
Max input rpm
- TA : 加速時ピークトルク (N・m)  
Acceleration peak torque
- TB : 瞬時最大トルク (N・m)  
Max. instantaneous torque
- F1 : 許容スラスト荷重 (N)  
Allowable thrust load
- F2 : 許容ラジアル荷重 (N)  
Allowable radial load
- TO : 許容定格トルク (N・m)  
Allowable rated torque

表1 荷重係数  
Table 1 Load coefficient

運転条件 Operating conditions	fw
衝撃のない円滑運転のとき In smooth operation with no impacts	1.0~1.2
普通の運転のとき In normal operation	1.2~1.5
衝撃・振動を伴う運転のとき In operation with impacts and vibrations	1.5~3.0

〈参考計算式〉 Reference calculation formula

〈速度パターン〉  
Velocity pattern

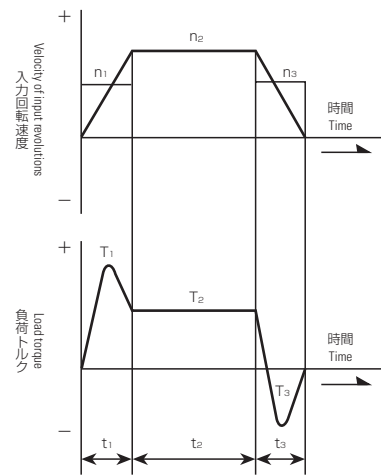

平均負荷トルク Average load torque

$$T_m = \sqrt[3]{\frac{n_1 t_1 T_1^3 + n_2 t_2 T_2^3 + n_3 t_3 T_3^3}{n_1 t_1 + n_2 t_2 + n_3 t_3}}$$

平均入力回転数 Average number of input revolutions

$$N_m = \frac{t_1 n_1 + t_2 n_2 + t_3 n_3}{t_1 + t_2 + t_3}$$

表2 運転条件  
Table 2 Operating conditions

項目 Item	起動時 Starting	定常時 Steady operation	停止時 Stoppage
負荷トルク Load torque N・m	T <sub>1</sub>	T <sub>2</sub>	T <sub>3</sub>
回転数 Number of revolutions rpm	n <sub>1</sub> (=0.5 n <sub>2</sub> )	n <sub>2</sub>	n <sub>3</sub> (=0.5 n <sub>2</sub> )
時間 Time sec	t <sub>1</sub>	t <sub>2</sub>	t <sub>3</sub>



クロスローラベアリングの計算 (JFRシリーズ) Calculation for Cross Roller Bearing (JFR Series)

最大負荷モーメント荷重 (M max) の計算 Max. Load Moment Load (M max)

$$M_{max} = F_{r_{max}} (L_r + L_c) + F_{s_{max}} \cdot L_s$$

$F_{r_{max}}$  : 最大ラジアル荷重 Max. radial load (N)

$F_{s_{max}}$  : 最大スラスト荷重 Max. thrust load (N)

最大負荷モーメント荷重が  $M_{max} \leq M_c$  であることを確認して下さい  
 Confirm that the max. load moment load is  $M_{max} \leq M_c$ .

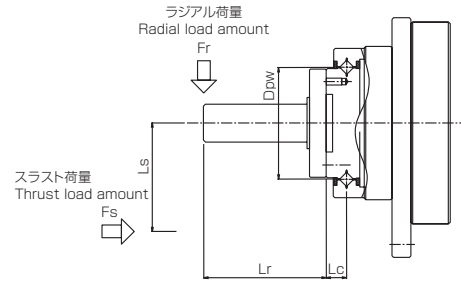

型式 Model	減速比 Reduction ratio	オフセット量 [Lc] Offset amount m	許容モーメント荷重 [Mc] Allowable moment load N · m	許容ラジアル荷重 Allowable radial load N	許容スラスト荷重 Allowable thrust load N
JFR60	1/10.5	0.0096	21	360	450
	1/15			520	600
	1/20			630	760
	1/30			720	900
JFR90	1/10.5	0.0131	74	770	1120
	1/15			1120	1650
	1/20			1300	1810
	1/30			1470	1980
	1/40			1640	2140
JFR120	1/10.5	0.0160	165	1750	1650
	1/15			2230	2670
	1/20			2490	3210
	1/30			2750	3760
	1/40			3010	4320

許容ラジアル荷重、許容スラスト荷重はクロスローラベアリングに純粋なラジアル荷重又はスラスト荷重のみ  
 どちらかがかかる場合に減速機寿命時間を満たす値です (ラジアル荷重 :  $L_r + L_c = 0$  スラスト荷重 :  $L_s = 0$ )  
 The allowable radial load is the value that satisfies the reduction gear life hours when the pure radial load is applied to the cross roller bearing, and the allowable thrust load is the value that satisfies the reduction gear life hours when the pure thrust load is applied to the cross roller bearing. (Radial load:  $L_r + L_c = 0$ , Thrust load:  $L_s = 0$ )

平均荷重の計算式 Calculation of Average Load

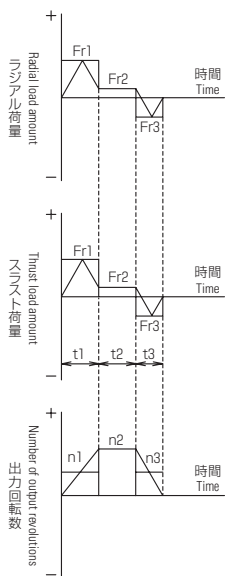

平均ラジアル荷重  $F_{ra}$  (N)

Average radial load

$$F_{ra} = \sqrt[10/3]{\frac{n1t1(|Fr1|)^{10/3} + n2t2(|Fr2|)^{10/3} + \dots + nntn(|Frn|)^{10/3}}{n1t1 + n2t2 + \dots + nntn}}$$

平均スラスト荷重  $F_{sa}$  (N)

Average thrust load

$$F_{sa} = \sqrt[10/3]{\frac{n1t1(|Fs1|)^{10/3} + n2t2(|Fs2|)^{10/3} + \dots + nntn(|Fsn|)^{10/3}}{n1t1 + n2t2 + \dots + nntn}}$$

平均出力回転数  $N_a$  (rpm)

Average number of output revolutions

$$N_a = \frac{n1t1 + n2t2 + \dots + nntn}{t1 + t2 + \dots + tn}$$

平均モーメント荷重  $M_a$  (N · m)

Average moment load

$$M_a = F_{ra}(L_r + L_c) + F_{sa} \cdot L_s$$

## ラジアル係数・スラスト係数の計算式 Calculation Formulas for Radial Coefficient and Thrust Coefficient

区分 Classification	X	Y
$\frac{F_s}{F_r + 2M/D_{pw}} \leq 1.5$	1	0.45
$\frac{F_s}{F_r + 2M/D_{pw}} > 1.5$	0.67	0.67

型式 Model	基本動定格荷重 Basic kinetic rated torque C (N)	ローラのピッチ円直径 Roller pitch circle diameter D <sub>pw</sub> (m)
JFR60	4600	0.0435
JFR90	10700	0.0652
JFR120	17600	0.0875

 荷重係数 Load Coefficient f<sub>w</sub>

荷重状態 Load state	f <sub>w</sub>
衝撃のない円滑運転のとき In smooth operation with no impacts	1.0~1.2
普通の運転のとき In normal operation	1.2~1.5
衝撃・振動を伴う運転のとき In operation with impacts and vibrations	1.5~3.0

 寿命計算 Life Calculation L<sub>h</sub> (hour)

クロスローラベアリングの寿命は  
次式により求めます

For the cross roller bearing,  
calculate the life hours by using the following formula:

$$L_h = \left( \frac{10^6}{60 \cdot N_a} \right) \cdot \left( \frac{C}{f_w \cdot P_c} \right)^{10/3}$$

 動等価ラジアル荷重 Kinetic Equivalent Radial Load P<sub>c</sub> (N)

$$P_c = X \cdot \left( F_r a + \frac{2Ma}{D_{pw}} \right) + Y \cdot F_s a$$

## 減速機をご使用にあたっての注意点 Attention in the Use Speed Reducer

- 選定時荷重係数をご考慮下さい。(f<sub>w</sub>値→P.47をご参照下さい。)

Consider load factor when select a model. (f<sub>w</sub> → refer P.47)

- 通常の起動・停止時に出力軸にかかるピークトルクの許容値を示します。

(注) 運転においては、加速時ピークトルクを越えない様、十分ご検討下さい。

The allowable peak torque applied to the output shaft at normal stop and start .

(Note) Care should be taken that the peak torque at acceleration not be exceeded during normal operation.

- 非常停止又は外部からの衝撃等により、出力軸に瞬間にかかる最大トルクの許容値を示します。

(通常使用条件での最大トルクではありません)

The max. instantaneous torque is max. allowable torque applied to the output shaft when the load is emergency-stopped or subject to an external impact.

(Note) This torque is not maximum torque under normal operating condition.

- ボール減速機にはセルフロック特性がありません。モータ電源OFFなどの入力解放時、不均衡な負荷の場合、回転する事がありますのでご注意ください。

Ball type speed reducer has no self-locking function. When unbalanced load is applied to input shaft even with power source OFF, be careful of shaft accidentally set in motion.

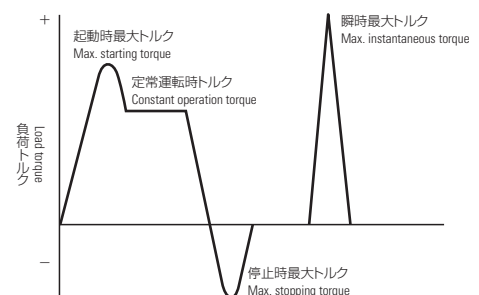

取付上の要領 Points of Installation

BR-Uユニット取付要点 BR-U Series Installation Point

このユニットは、短寸をねらいとしていますので、出力軸支持ベアリングが1コになっています。従って出力フランジ端面に0.02~0.03の振れが発生しますので、平行回転精度の必要なものはご注意ください。ギヤ、プーリー等偏荷重、重荷重の場合は必ず下記のように別支持を設けて下さい。

尚、本体の取付けは、(A)の別フランジ方式、又は(B)のように本体に穴を貫通させ、長ボルトで固定することもできます。P.37のその他のオプションをご参考下さい。又、出力軸フランジ端面は減速比や予圧力によって軸方向に最大±0.5の変化が生じます(C)。その為、負荷軸は、軸方向の逃げが可能な構造として下さい。

The BR-U series are designed for a compact installation profile, and as such, the output flange is supported by one bearing. Without additional support on the output flange, the deflection will be present in the amount of 0.02-0.03mm. Additional support of the output flange should be provided when parallel rotational accuracy is concern, if heavy axial loading or heavy loading is to be encountered. Loads of this type can be expected from use of a pulley or gear.

The main body of ball reducer is fixed by either an additional flange mounting shown in (A) or tightening long bolt shown in (B) by boring through holes on the main body. Please refer to other options in P.37. As the output shaft at the end of flange may vary max. ± 0.5mm toward axial direction by reduction ratio or preload pressure as shown in (C). Therefore, the load shaft should have the structure that enables travel toward axial direction.

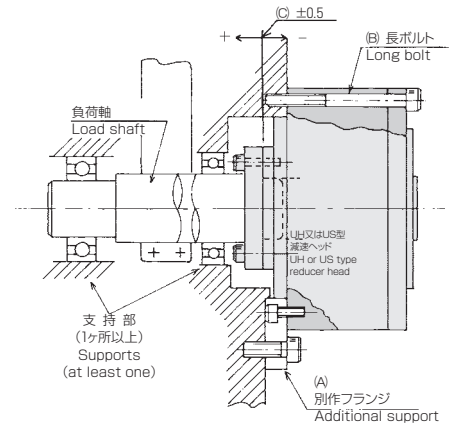

減速機・モータ取付要領 Installation of Reduction Gear and Motor

減速機とモータ取付の際は下記手順にて行ってください。

Install the reduction gear and the motor by using the following procedures:

1. 減速機入力軸内径とモータ軸をゴミ・油などをきれいに取り除いてください。  
Clean the inside diameter of the input shaft of the reduction gear and the motor shaft of dirt, oil, etc.
2. 減速機入力軸のセットカラーのボルトをモータアタッチメント作業穴の位置に合わせてください。  
Position the set collar bolt of the input shaft of the reduction gear of to the work hole of the motor attachment.
3. 減速機とモータが傾かないように注意して静かに奥まで挿入しモータをボルトで固定してください。  
Insert the set collar bolt to the depth slowly, being careful not to allow the reduction gear and the motor to tilt, and fix the motor with the bolt.
4. セットカラーを所定の締付トルクにて固定してください。  
Fix the set collar at the specified tightening torque.

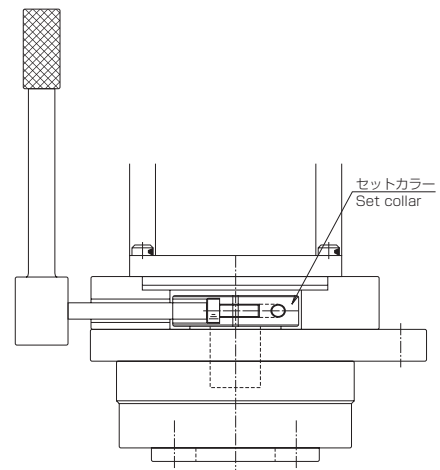

クランプボルト締付トルク一覧 Tightening Torque Table for Clamp Bolts

クランプボルト Clamp bolt	締付トルク Tightening torque N · m
M4	4.5
M5	9.0
M6	15.3

必ず上記締付トルクにて締結してください。

締付トルクが満たない場合、滑り等の原因になりますのでご注意願います。

Be sure to fix at the above tightening torque. Please note that insufficient tightening torque will cause slipping and/or other problems.

※トルクレンチの使用を推奨します。  
※Use of a torque wrench is recommended.

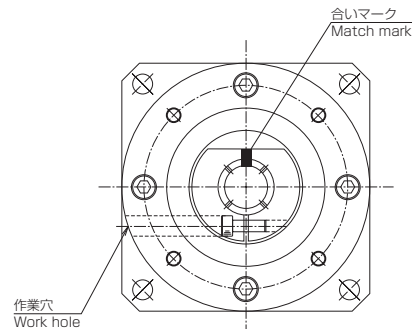

注：セットカラーは減速機の balancer の役目も持っています。位置ずれ防止の為に止めネジにて固定をしておりますが、万一動いてしまった場合には入力軸と合いマークの位置を合わせてから締付を行っていただく様、お願いいたします。

The set collar also serves as a balancer for the reduction gear. It is fixed with a set screw to prevent displacement. However, if it should be displaced, position the input shaft to the match mark, and then fasten the set screw.

## モータ直接入力 (全シリーズ) Bore Type Input Direct Mount to Motor (All Series)

- 穴タイプの減速機には、各モータをダイレクトに取り付けることが可能です。  
The motor can be directly connected to the ball reducer as shown in the graphs.
- モータ軸は、キータイプ・テーパ軸タイプ等ありますが、いずれの場合にも下図の様なモータアタッチメントが必要です。  
Motor attachment shown at drawing will be needed in the case of the direct input method with a key type or a tapered bushing type.
- ご注文の際に、モータ仕様を提示して頂ければ弊社で製作致します(S45C又はアルミ製)。もちろんユーザー様にて製作して頂いても結構です。  
The adapter flange can be customer-supplied, or supplied by us. Please provide all motor data for dimensional accuracy. The ball reducer assembled with the adapter flange will be delivered to customer when we provide the adapter flange. The adapter should be made of S45C or aluminum.
- ユーザー様にて製作の場合、モータ自身の芯ぶれを考慮し、減速機側のはめ合いはH7、モータ側はE7として下さい。モータ軸に負担がかからない様に挿入し、締付ボルトを均等に締めて下さい。  
Customer-supplied flange adapter should be finished to H7 on the ball reducer side of the flange and to E7 on the motor side of the flange. The tightening bolts should be tightened equally in considering motor shaft deflection.

## キー溝タイプ (BRシリーズのみ) Keyway Type (BR Series Only)

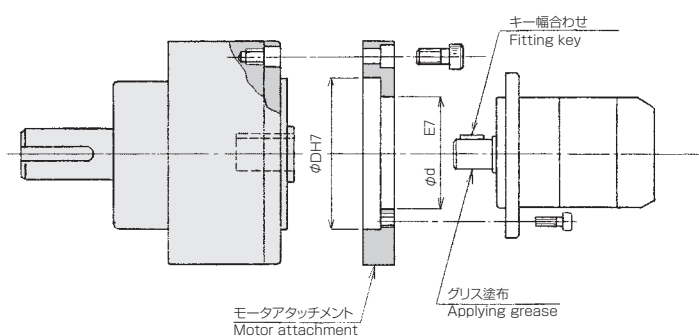

減速機側の入力軸キー幅公差は、ご指定のない場合はP9です。モータ軸を挿入するときは、必ずキー合わせをして下さい。ムリに挿入しますとモータ・減速機を破損することがあります。軸にグリスを塗布して挿入して下さい。(フレッチングによる軸の喰い付きを防止します。)

The tolerance of the key width on the input shaft of the ball reducer is P9 unless otherwise specified. Check for proper fit between key and keyway in inserting the motor shaft. Excessive insertion of the motor shaft may result in damaging the ball reducer and the motor. Coat the shaft with grease before inserting the shaft into the bore input, which is preventing the shaft from being stuck in the bore fretted by frictional erosion.

## 丸軸タイプ (BRシリーズのみ) Round Shaft Type (BR Series Only)

### D・Aカットタイプ “D” or “A” cut type

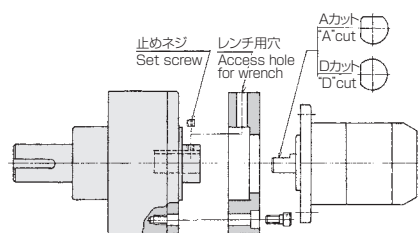

(注記) 小型モータ100W以下に限ります。  
(Note) This is for 100w or smaller motor only.

小型モータであればDカット(一面カット)あるいはAカット(二面直角カット)を追加し、止めネジで固定します。ネジにロックタイト等ゆるみ止め剤を塗布して下さい。

The output shaft of the smaller sizes of the stepping motors should have an “A” cut or “D” cut as shown in the left diagram. And the set screws are tightened in place. Locktite can be applied to the threads to prevent the screws from loosening.

## テーパ軸タイプ (UHタイプのみ対応) Tapered Shaft Type Input (Available Only for UH Models)

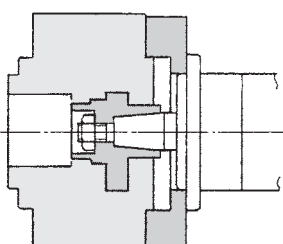

小型機種は対応できません。モータ仕様を前もって提示頂ければ、その様に設計・製作致します。テーパ軸前端ネジナットは、出力軸側から締める構造になりますのでご留意下さい。

The tapered shaft type input is not applicable for small size. The prior information of the motor specifications enable us to design and make the ball reducer for the tapered shaft type input. Note that this coupling is designed so that the tightening nut must be accessed through the output shaft side of the ball reducer as shown in the diagram.





## ノンバックラッシュTCG・SFPシリーズ Non-backlash TCG・SFP Series

### TCG・SFP

Trochoid Cam Gear

ボールねじ・ラック&ピニオンを超えた直線・曲線駆動システムの提案

Introduction of linear and curvilinear drive system superior to ball-type screw and rack & pinion.

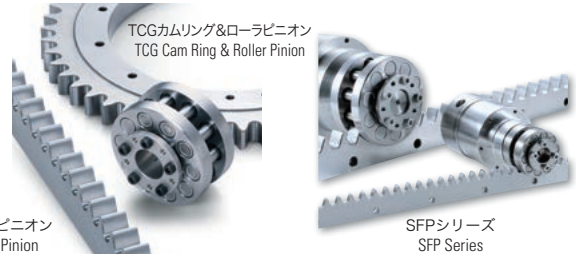

TCGカムラック&ローラピニオン  
TCG Cam Rack & Roller Pinion

SFPシリーズ  
SFP Series

## ノンバックラッシュボール減速機シリーズ Non-backlash Ball Reducer Series

### BR

Ball Reducer

ボールにより軽快高効率・高精度を実現したノンバックラッシュ減速機

Non-backlash reducer with smoothness, high efficiency and high precision realized by the employment of balls



薄型ボール減速機 JFRシリーズ  
Just-fit Ball Reducer JFR Series



ボール減速機 BRシリーズ  
Standard Type Ball Reducer BR Series

## パールデックスシリーズ PearlDex Series

### PDW

Pearl Index System

高精度でありながら低価格を実現したインデックス

Index Mechanism With High Accuracy At Low Price



パールデックス PDWシリーズ  
PearlDex PDW Series

## インデックスシリーズ Index Series

### MINIDEX・MINITABLE

Indexing Actuator

複合動作をユニット化、シンプル構造で使いやすいエア・アクチュエータ

The compound operation is made a unit. Air actuator that is easy to use because of simple structure.



ミニテーブル MTシリーズ  
Minitable MT Series



ミニデックス MDFシリーズ  
Minidex MDF Series

#### 【ボール減速機の特性と特殊仕様等】

■ボール減速機は非常に効率がよい為、セルフロック機構はありません。セルフロックを期待される使用方法の場合はこの点を十分ご注意ください。■標準仕様は防水、防塵対策はしていませんが、特殊仕様にて、製作いたしますので、お問合せ下さい。

#### ボール減速機適用上のご注意



●本製品の最終使用者が軍事関係であったり、用途が兵器などの製造用である場合には、「外国為替管理法」の定める輸出規制の対象となることがありますので、輸出される際には十分な審査及び必要な輸出手続きをお取り下さい。●本品は、人命にかかわるような状況下で使用される機器などに使用される目的として、設計、製造されたものではありません。●本品を特殊用途(航空宇宙用・原子力関連・乗用移動用・医療機器など)でのご使用をご検討の際は、弊社までご一報下さい。●本品は厳重な品質管理のもとに製造しておりますが、万一本品が故障することにより人命にかかわるような重要な設備、重大な損失の発生が予想される設備への適用に際しては、重大事故にならないよう安全装置を設置して下さい。●本製品を特殊環境(クリーンルーム、食品など)に使用される場合は、あらかじめ当社代理店または最寄りの営業所へご連絡下さい。

■このカタログ記載内容は2023年5月現在のものです。■本カタログに記載されている仕様・寸法等は改良のため、予告なく変更することがあります。■商品のカラーは印刷のため、実物と異なって見える場合があります。■本品の無償修理期間は、弊社が規定しております仕様条件内でのご使用を前提に、出荷後1年または実稼動2,500時間のどちらか早い到達時期といたします。■万一保証期間内において、明確に本品の品質起因による故障、不備が発生した場合、その対応を無償にて実施いたします。但し実機よりの脱着に関する工数、関連諸経費などは弊社負担外とさせていただきます。■お客様にて分解、改造等をなされた場合の無償修理対応は致しかねます。■弊社では海外における保守およびサポートは行っていません。■不具合・修理のご依頼は、お買上げの販売店又は弊社サービス部までお問合せ下さい。

#### 【Characteristics and Special Specifications】

■A ball reducer does not have self-locking mechanism due to its high efficiency. Care should be taken in an application where self-locking mechanism is expected. ■Water-or dust-proof is not treated in the specification of a standard ball reducer. If needed, Kamo Seiko can make a ball reducer with a special specification upon request. Please contact with Kamo Seiko or local distributor.

#### Cautions for use of Ball Reducer



● If the user of the product is a military interest or if the product is to be used in the manufacture of weapons, the product may be subject to export regulations prescribed in the Foreign Trade Control Act. Confirm these conditions before exporting the product and take the necessary steps. ● Our products are not designed and manufactured to be used for the machines or equipment which may affect people's lives. ● Please contact with Kamo Seiko or local distributor if the products are used for the special applications such (aero-space, atomic power, vehicle, medical and etc.). ● Although our product has been manufactured under our strict quality control, it is advisable to provide a safety device when our product is applied to a perilous use. This is to avoid any accident that could cause serious damage to people or property in case of a problem with our product. ● When this product is used in a special environment (clean room, food handling facility, etc.), please contact with Kamo Seiko or local distributor.

■The contents in the catalog is as of May, 2023. ■Specifications and dimensions are subject to change without notice. ■Product colors may look different from the catalog due to print. ■Q-Ten series ball reducers are warranted to be free from defects in material and workmanship for the shorter period of either 12 months after the date of the shipment or 2,500 hours of operation on condition that the Q-Ten ball reducers are installed properly and operated under conditions specified by Kamo Seiko. ■Defects in material and/or workmanship will result in replacement of defective unit by Kamo Seiko. The unit should be returned with freight prepaid to Kamo Seiko Corporation. ■Any cost in removing and/or installing the unit from/on the machine or facility should be owned by customer side. ■Kamo Seiko will not accept the free repair in case the unit is disassembled or modified. ■Kamo Seiko does not offer the services for maintenance and installation abroad. ■Please contact with Kamo Seiko or the local distributor for nonconformity or repair.

## 加茂精工株式会社

本社営業部  
〒470-0424 愛知県豊田市御作町亀割1166番地  
TEL. 0565-76-0029(営)  
URL www.kamo.co.jp

KAMO FA (韓国)  
ソウル特別市杓川區加山洞550-1 A P T 形工場T. CASTLE1洞216号  
TEL. 02-761-5621  
URL www.kamofa.co.kr E-mail kamofa@kamofa.co.kr

加茂伝動科技(南京)有限公司(中国)  
南京市秦淮区太平南路166号远洋国际中心北区3幢1单元901室 邮编:210001  
TEL. 025-5223-0890  
URL www.kamoasia.com E-mail ztc@kamoasia.com

## KAMO SEIKO CORPORATION

HEAD OFFICE  
1166 Kamewari, Mitsukuri-cho, Toyota-city, Aichi-prefecture 470-0424, JAPAN  
Tel. +81-565-76-0029  
URL www.kamo.co.jp

KOREA  
KAMO FA 1Dong-216Ho IT Castle' Gasan-dong, Geumcheon-gu, Seoul, Rep of KOREA  
Tel. +82-2-761-5621  
URL www.kamofa.co.kr E-mail kamofa@kamofa.co.kr

CHINA  
KAMO DT RM901, BLK3, North Ocean Int'l Center, 166 South Taiping Road, Nanjing,  
China ZIP:210001  
Tel. +86-25-5223-0890  
URL www.kamoasia.com E-mail ztc@kamoasia.com

kamo

Yes We can! Yes I can!